

Ensure that the installation of your product conforms to all the indications given below.

Fig. 1

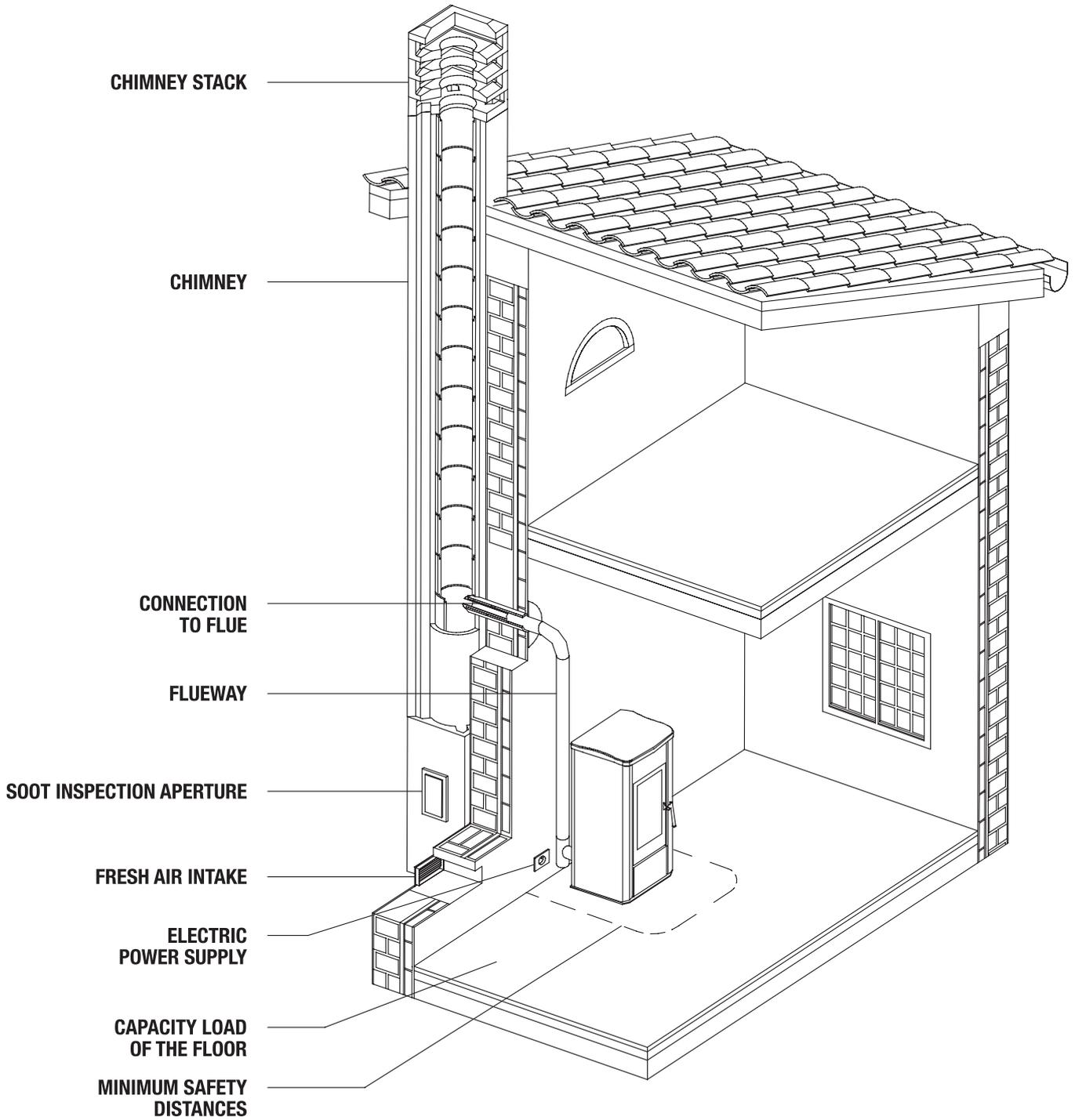

DT2030321-01

English

Every appliance must have a vertical flue pipe operating by natural draught to discharge the combustion gases outdoors.

The flue must:

- comply with regulations in force in the place of installation of the appliance;
- be tight to the products of combustion, waterproof, suitably insulated, made with materials resistant to the corrosion of the gases and to stress;
- be connected to just one stove, fireplace or extraction hood (Fig. 2);
- be properly sized, with constant free internal section, equal to or greater than the diameter of the flue pipe of the stove and at least 3.5 m in length (Fig. 2);
- be mainly in a vertical position with a deflection from the axis of no more than 45° (Fig. 2);
- be at a suitable distance from combustible or flammable materials, ensured by an air gap or suitable insulating material;
- be of uniform internal section, preferably round. Square or rectangular sections must have rounded corners with a radius of at least 20mm and a maximum ratio between the sides of 1.5 (Fig. 3-4-5);
- the walls must be smooth if possible and without narrowing; bends must be regular and without discontinuity (Fig. 6).

Fig. 2

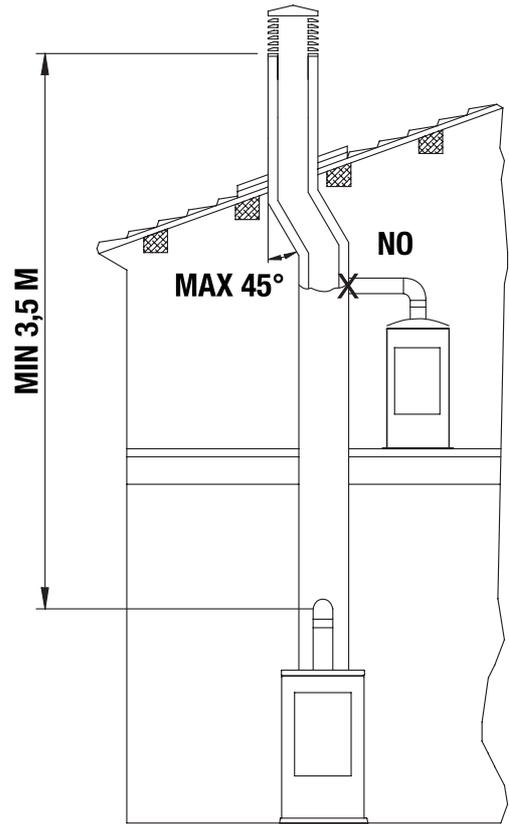

DT2030049-00

- ⊘ It is forbidden to make fixed or mobile apertures on the flue pipe to connect appliances other than the one to which it is already connected.
- ⊘ It is forbidden to pass other air ducts or service pipes inside the flue pipe, however large it is.
- ⚠ If the flue pipe is an incorrect size or installed other than in compliance with the above instructions, Gruppo Piazzetta S.p.A. cannot be held liable for malfunctioning of the product, damage to property or injury to persons or animals.

Fig. 3

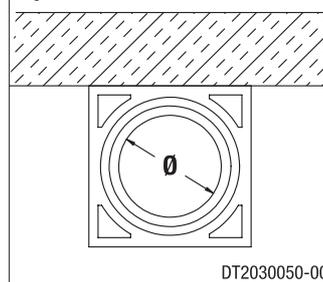

DT2030050-00

Fig. 4

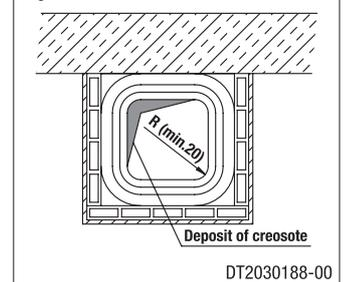

DT2030188-00

Fig. 5

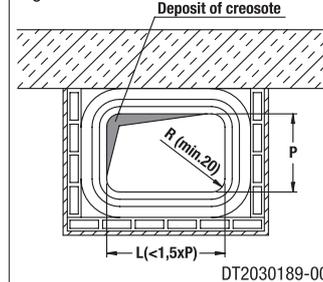

DT2030189-00

Fig. 6

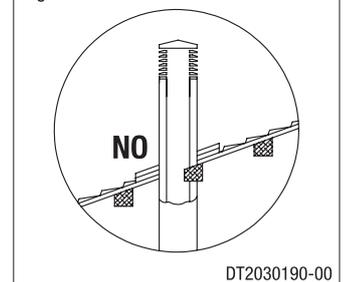

DT2030190-00

## 1.2 SOOT INSPECTION

DT2010031-01

We recommend that the flue must have a chamber for collecting solid matter and any condensate located below the connection and which may be easily inspected by means of an airtight door. (Fig. 1)

### 1.3 CHIMNEY STACK

The chimney stack is a device fitted on the top of the chimney that is designed to aid dispersion of the products of combustion in the atmosphere.

The chimney stack must comply with the following requirements:

- it must have an internal section and shape the same as the flue (A);
- it must have a useful outlet section (B) of not less than twice that of the flue (A);
- the part of the chimney that emerges from the roof or remains in contact with the outside (e.g. in the case of a flat roof), must be covered with brick or tile elements and in any case well insulated;
- it must be built in such a way as to prevent the penetration of rain, snow and foreign matter into the flue and to ensure that in the event of winds from all directions and angle, discharge of the combustion products is assured (chimney stack with down-draught cowl).

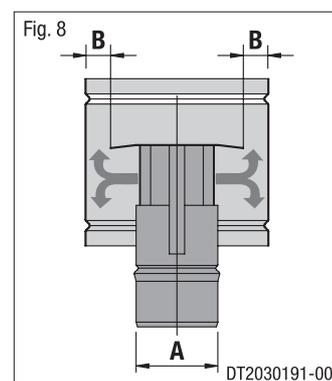
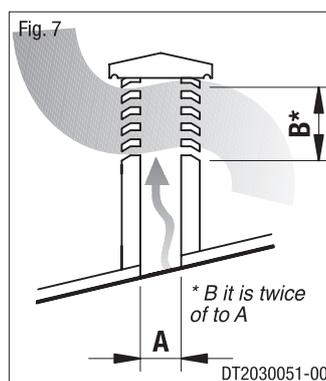

#### Recommended distances for correct chimney operation.

To ensure trouble-free operation of the chimney and allow correct dilution of the products of combustion in the air, the chimney stack must be installed at the distances given below:

- 6-8 metres from any buildings or other obstacles that are higher than the chimney stack;
- 50 centimetres higher than any obstacles located at a distance less than 5 metres;
- outside the reflux area. The size and shape of this area differ according to the angle of inclination of the roof and it is therefore necessary to adopt the minimum heights shown below.

**Example:** Check the slope of the roof (column  $\alpha$ ), and the anticipated distance of the chimney stack from the axis of the ridge (column A), if the distance is greater than "A" the height of the chimney stack may be read in (column H); if the distance is less than "A" the chimney stack must rise above the ridge by 0.5 metres.

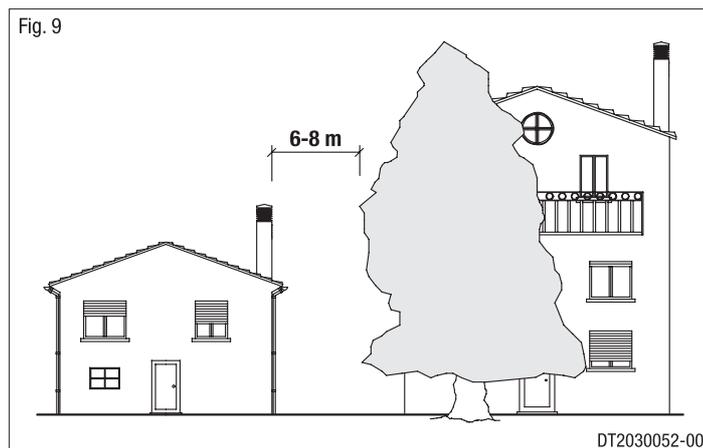

Fig. 10

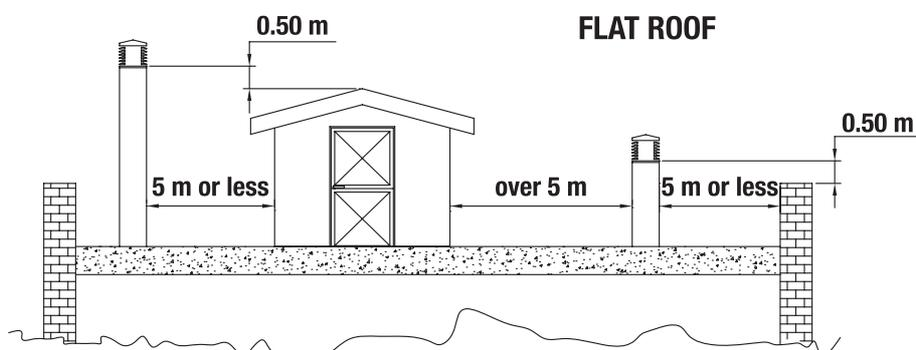
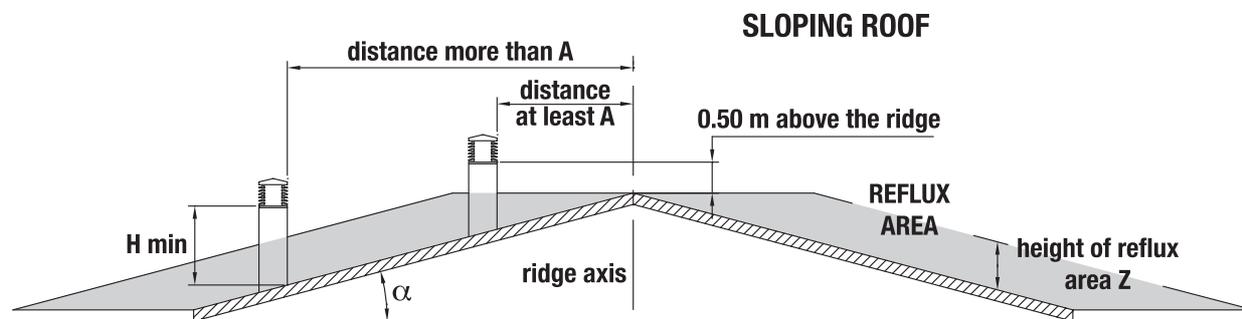

Fig. 11



Pitch of the roof	Horizontal width of reflux area from ridge axis	Minimum height of outlet from roof	Height of reflux area
$\alpha$	A	H	Z
15°	1.85 m	1.00 m	0.50 m
30°	1.50 m	1.30 m	0.80 m
45°	1.30 m	2.00 m	1.50 m
60°	1.20 m	2.60 m	2.10 m

To ensure trouble-free operation the stove/fireplace must have the necessary air available for combustion and this is provided through the fresh air intake.

The fresh air intake must:

- have a total free cross section at least equal to the size given in the paragraph **“TECHNICAL DATA”**;
- be protected by a grille or suitable guard provided it does not reduce the minimum recommended section;
- be in a position whereby it cannot be obstructed.

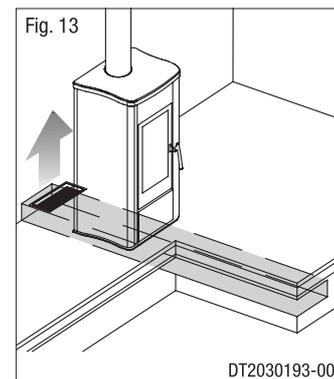
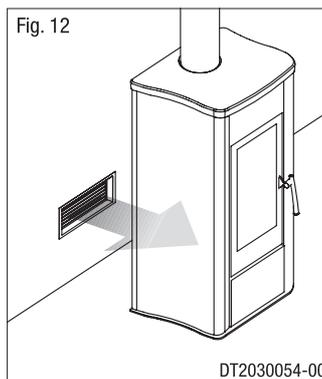

The airflow necessary for the fire may be obtained in different ways:

- through a fresh air intake direct into the room of installation;
- with ducting through pipes direct to the room of installation, increasing the recommended minimum free cross section by at least 15%;
- from an adjacent room to the place of installation provided this air flows freely through permanent apertures communicating with the outside.

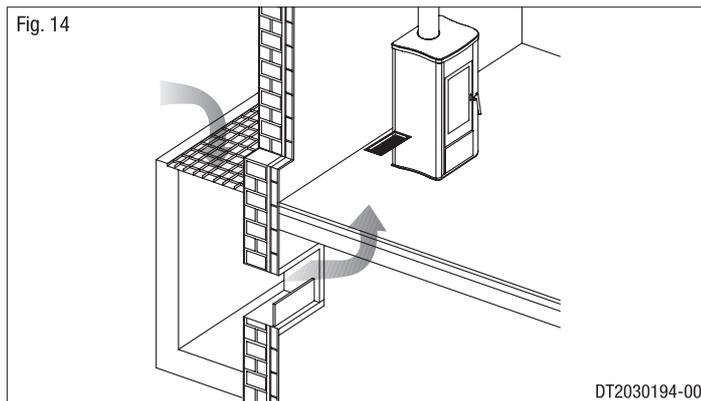

- ⚠ The adjacent room from which air is taken must not have a low pressure compared to the exterior due to a counter draught caused by the presence in that room of another appliance in use or of a suction device.**  
**The permanent apertures in the adjacent room must comply with the requirements given above.**

- ⊘ Combustion air must not be taken from adjacent rooms used as a garage or a combustible materials store or for activities posing a fire hazard.**

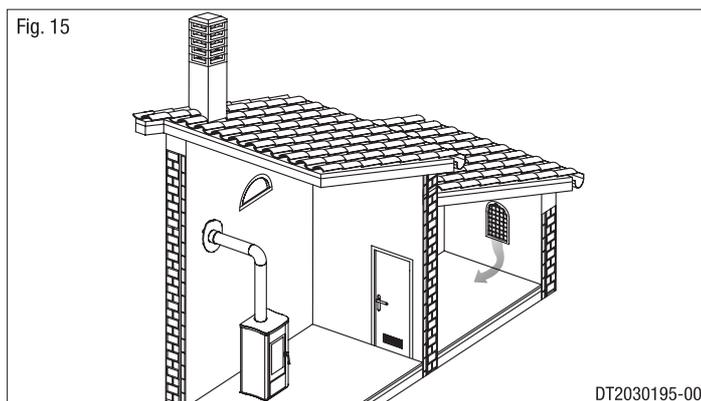

## 1.5 INSTALLATION ENVIRONMENT

The appliance should be installed in a location which allows safe and convenient use as well as easy maintenance. If the product being installed requires an electrical socket, the room must also be provided with an earthed power supply in accordance with current regulations.

The room where the appliance is to be installed must comply with the following requirements:

- ⚠ They must not be used as a garage, store for combustible material or for activities with a risk of fire.**
- ⚠ They must not be in a vacuum in relation to the outside environment due to the effect of contrary draught caused by the presence in the room where the fi replace is installed of another appliance or an extractor device.**
- ⚠ Do not use two stoves, a fireplace and a stove, a stove and a wood-fired cooking range, etc. in the same environment, since the draught of one could affect the draught of the other.**

- Devices suitable for cooking food with relative hoods without an extractor fan may only be used in kitchens.
- Gas appliances of type C are allowed (refer to current legislation and regulations in the place of installation).

- ⊖ Gas appliances of type B are not allowed (refer to current legislation and regulations in the place of installation).
- ⊖ The stove or fireplace must not be used simultaneously with collective type ventilation ducts with or without extractor fan, other devices or other appliances such as: forced ventilation systems or other heating systems using ventilation to change the air. Such systems could cause a vacuum in the environment of installation even if installed in adjoining or communicating rooms.
- ⊖ The stove or fireplace must not be used: in stairwells except in buildings with no more than two apartments; in corridors for common use; in bedrooms; in bathrooms or shower-rooms.

## 1.6 CAPACITY LOAD OF THE FLOOR

DT2010032-00

Check the load-bearing capacity of the floor, referring to the weight of the product given in the paragraph “**TECHNICAL DATA**”. If the floor does not have a suitable load-bearing capacity, adequate countermeasures must be taken.

## 1.7 HEATING CAPACITY

DT2010130-01

Check the heating capacity of the appliance by comparing the rated power given in the paragraph “**TECHNICAL DATA**” with the power required by the environment to be heated.

The energy requirement may be calculated approximately by multiplying the square metres of area by the height of the ceiling; the result is then multiplied by a coefficient, which depends on the degree of insulation of the building, that is, on internal and external factors of the dwelling:

- **Internal factors:** type of window and door frames, thickness of the insulation and walls, type of building materials, presence of stairwells, walls with extensive glazing, high ceilings, position of the rooms to be heated in relation to other adjacent heated or unheated rooms, ....
- **External factors:** geographical position, average outdoor temperature, exposure, wind speed, latitude, altitude, ...

### **Example of approximate calculation of the energy requirement to heat a fixed volume to 18/20° C:**

The **coefficient** that is normally **used** is determined according to the real conditions as they occur case by case.

- From **0.04** to **0.05 kW** per cubic metre in a **well insulated environment**.
- From **0.05** to **0.06 kW** per cubic metre in a **poorly insulated environment**.

### **3 rooms measuring 20 m<sup>2</sup> X (H ceiling) 2.7 m = 162 m<sup>3</sup> (volume)**

In an environment with a good degree of insulation, an average value (coefficient) of 0.045 kW may be taken

**162 (volume) X 0.045 (kW) = 7.3 kW necessary (6300 kcal/h)**

Conversion 1 kW = 860 kcal/h

⚠ Consult a heating technician or engineer for a correct check and calculation of the requirement of the environments to be heated (see “**REFERENCE STANDARDS**”).

⚠ Rated power being equal, products with the Multi-fire system can evenly distribute heat throughout the rooms to be heated.

## 1.8 MINIMUM SAFETY DISTANCES

The position of the product inside the room must take into account not only the regulations, heating requirements, the shape of the installation and adjoining rooms but also accessibility and use during maintenance operations.

It is therefore recommended that an area greater than the one indicated, is left around the appliance to facilitate maintenance interventions and prevent overheating problems.

The walls adjacent to the product, the structure above the appliance and the floor on which the appliance rests must be in non-flammable material.

Installation is allowed near heat sensitive or flammable objects as long as there is suitable insulation protection and distances are respected (for example, in the case of a wooden floor, a protective base must be used).

Construction elements which are already present such as wooden beams or a counter-hood and all trims in combustible material must be positioned outside the irradiating range of the product and away from any grilles or slits from which hot air is released. Suitable insulating material must be used.

**⚠ Keep any flammable products such as: wood furniture, carpets, curtains, flammable liquids, etc.. well away from the product during operation (minimum 80 cm).**

**⚠ The product must be installed in compliance with the appropriate safety distances from the walls and objects. Failure to comply with these indications could result in fire.**

Please refer to the section “TECHNICAL SPECIFICATIONS” and installation instructions for the values.

**⚠ Distance (F): for information regarding the safety distances, installation methods, maintenance, safety and insulation, please refer to the indications provided by the flue pipe manufacturer.**

**⚠ The minimum distance (F) from heat sensitive construction elements or inflammable materials must be respected along the entire length of the flue pipe (for example, cladding, walls, beams or wooden ceilings, etc.), furthermore, when a pipe passes through a wall or ceiling, particular installation methods must be applied.**

**⚠ In order to ensure safety where there may be the risk of accidental contact with the flue pipe, the external surface must be sufficiently protected in compliance with regulations and instructions provided by the flue pipe manufacturer.**

Fig. 16

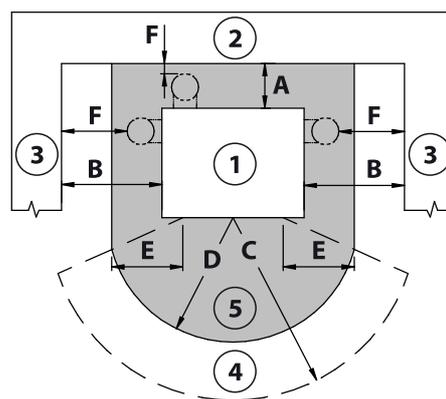
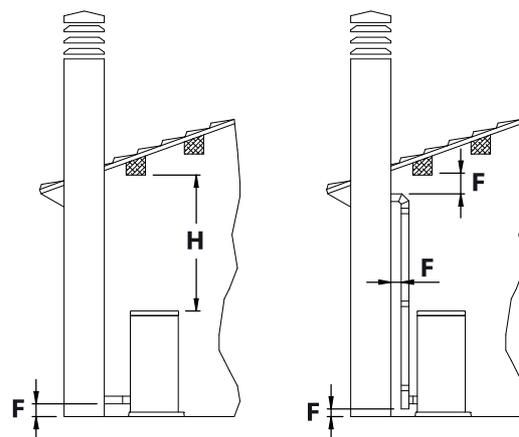

Fig. 17



### Key:

1	Appliance
2	Rear wall
3	Side wall
4	Radiant area of the fireside opening
5	Floor protection
A	Product air distance from rear wall
B	Product air distance from side walls
C	Area clear of flammable objects
D	Distance of front floor protection overhang
E	Distance between inside edge of fireside opening and the edge of the floor protection
F	Distance between the flue pipe and heat sensitive construction elements
H	Free distance from the upper edge of the product

## 1.9 FLUEWAY

**⚠ The pellet stove is not the same as other stoves. It has a forced draught of flue gas by a fan, which keeps the firebox in a vacuum and the entire flueway slightly pressurised. For this reason the flue must be completely airtight and correctly installed to ensure both trouble-free operation and user safety.**

- The flueway **must be made** by specialised personnel or firms, as outlined below.
- The flue must be installed in such a way as to guarantee that periodic cleaning can be carried out without dismantling any parts whatsoever.
- Pipes should **always** be sealed with silicone (**not cement-based sealants**) or specially adapted gaskets/seals, which retain their strength and elasticity at high temperatures (250°C), and should be fixed with 3.9 mm  $\varnothing$  self-tapping screws.

**⚠ Using the relative pipe clips, fix the flue to the wall so that it does not weigh on the smoke fan.**

**⊖ Do not install dampers or valves that could block the passage of flue gas.**

**⊖ Do not connect to a flueway into which other appliances (boilers, extractor hoods, etc.) discharge fumes or vapours.**

### Pipes and maximum usable lengths

Pipes of painted aluminium-clad steel (minimum thickness 1.5mm), stainless steel (AISI 316) or enamelled steel (minimum thickness 0.5mm) with a nominal diameter of 80 or 100 mm (for pipes which run inside the flue maximum diameter 150 mm) can be used.

The male-female connectors must have a minimum length of 50 mm. The diameter of the pipes depends on the type of installation. The stove was designed to take 80 mm diameter pipes but, as shown in Table 1, in some cases the use of double-lined 100 mm diameter pipes is recommended.

**⚠ Losses in pressure associated with a 90° bend can be compared to those incurred by one metre of pipe. An inspectable union-tee can be considered equivalent to a 90° bend.**

**EXAMPLE:** if installing a section greater than 4.5 m in length with 80 mm diameter pipe, calculate the maximum usable length in the following ways:

- If a maximum of **three 90° bends** are used, the maximum length of the section will be **4.5 m**.
- If a maximum of **two 90° bends** are used and bearing in mind that a 90° bend can be replaced by one metre of pipe, the maximum length of the section will be **4,5 m+1 m=5,5 m**.
- If a maximum of **one 90° bend** is used and bearing in mind that a 90° bend can be replaced by one metre of pipe, the maximum length of the section will be **4,5m+1 m+1 m=6,5 m**.

Where 100 mm diameter pipe must be used, connect it to the stove flue outlet with a 80 mm union-tee then use a 80 mm/100 mm adaptor (not supplied by Piazzetta) (Fig. 18).

### Union-tee

The use of this type of fitting must allow for the collection of condensate mixed with soot, which builds up inside the pipe. It must also permit periodic cleaning of the flue without the need to disassemble the pipes. This type of fitting can be bought at Piazzetta retail outlets together with the pipes.

An example is given below of a flueway connection, which allows complete cleaning without having to disassemble the pipes (Fig. 19).

TYPE OF INSTALLATION	WITH 80 mm DIAMETER PIPE	WITH DOUBLE-WALLED 100 mm DIAMETER PIPE
Maximum length (with three 90° bends)	4.5 m	8 m
For installations more than 1200 m above sea level	-	Obligatoire
Maximum number of bends	3	4
Length of horizontal sections with minimum 3% gradient	2 m	2 m

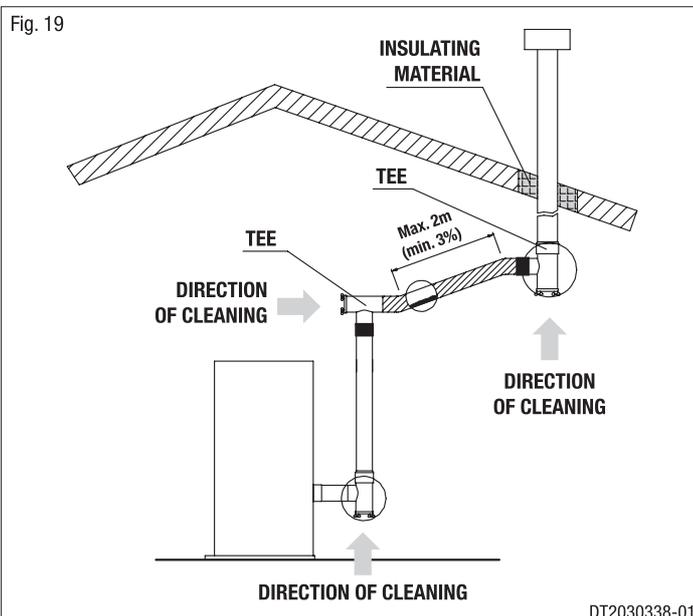
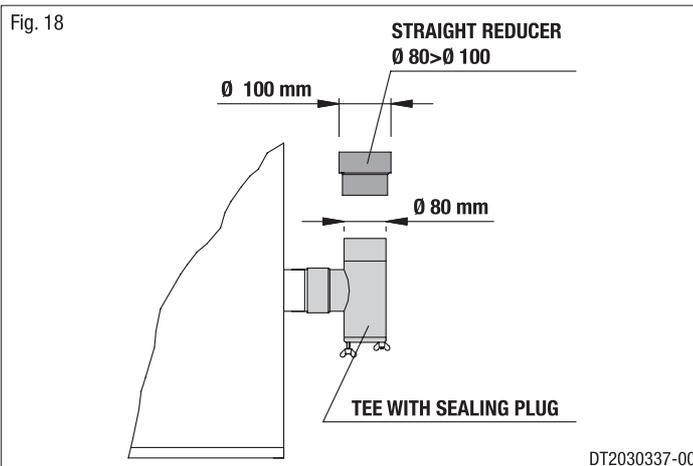

If you wish to use an existing chimney it is strongly recommended that you have it checked by a professional chimneysweep to ensure that it is completely airtight. The reason for this is that the smoke, because it is slightly pressurised, can infiltrate any cracks in the flue and escape into living spaces. If upon inspection you find that the chimney is not completely sound, it is recommended that you insert piping made of new material. If the existing chimney is wide enough we recommend a pipe with a maximum diameter of 150 mm. It is also recommended that you insulate the chimney flue (Fig. 20-21).

Pipes and bends made by Gruppo Piazzetta S.p.A. are recommended for connection to the flueway, since they are sized to fit the flue outlet of the appliance.

Other pipes may be applied after adaptation and checking of the compatibility of the coupling, taking into account that the pipes and bends must be made in compliance with current regulations. In this case, however, Gruppo Piazzetta S.p.A. only guarantees trouble-free operation for parts that it manufactures and that are used according to specifications.

- If the connector has to pass through partitions or walls of inflammable or heat-sensitive materials, or through load-bearing walls, create an insulating barrier equal to or greater than 10cm around the connector using mineral-based insulating material (rock wool, ceramic fibre) with a nominal density greater than 80 kg/m<sup>3</sup>.
- If the connector has to pass through **non-flammable partitions or walls**, create an insulating barrier equal to or greater than 5cm around the connector using mineral-based insulating material (rock wool, ceramic fibre) with a nominal density greater than 80 kg/m<sup>3</sup>.
- Check that the connection to the flueway is gas/smoke-tight, since the appliance operates in a vacuum.
- Check that the pipe does not penetrate too far into the flueway, thereby choking the pipe for the passage of smoke and combustion gases.

**⚠ Ensure that all installation work is carried out to professional standards.**

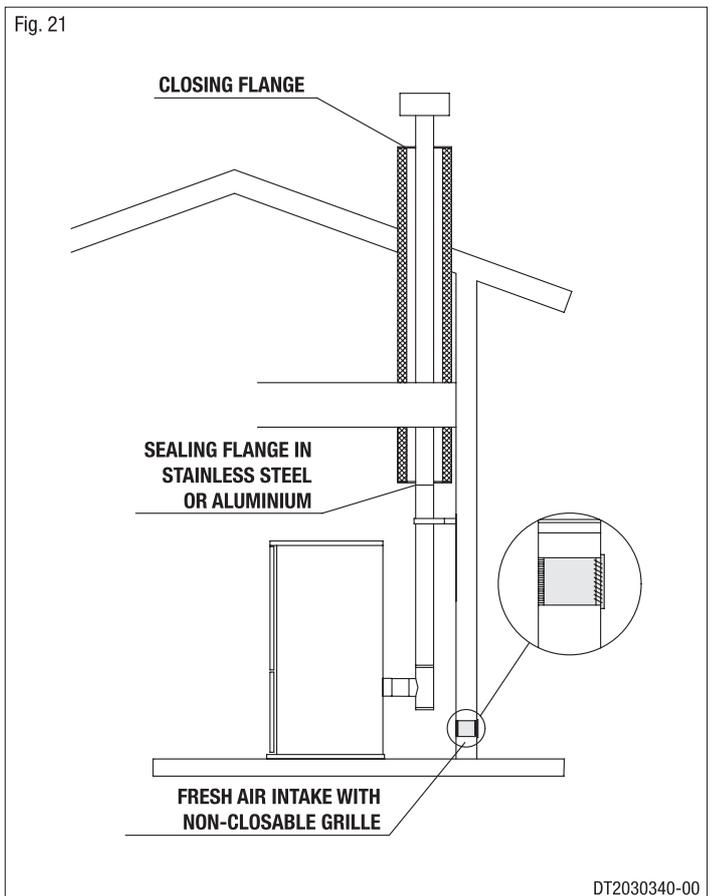
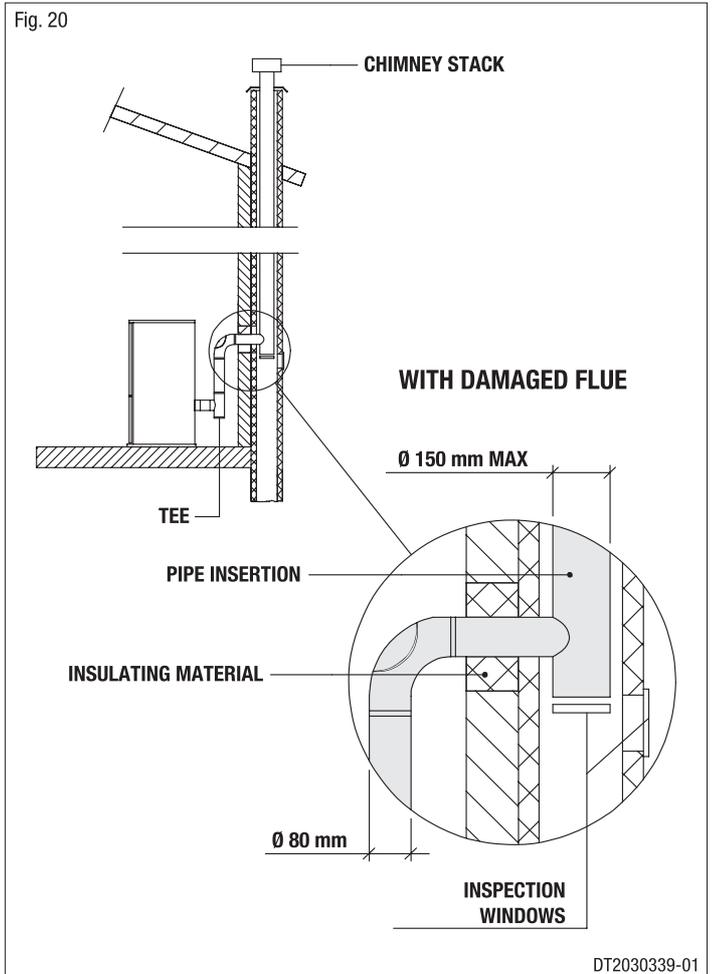



## 1.11 USING AN EXTERNAL FLUE

An external flue can be used provided it complies with the following requirements:

- use only insulated stainless steel pipes (double-lined) fixed to the outside wall of the building (Fig. 22);
- there must be an inspection opening at the base of the flue to permit periodic checks and maintenance;
- the flue must be fitted at the top with a chimney stack with down-draught cowl, also ensuring compliance with the safety distance from the roof ridge as outlined in the section entitled “**CHIMNEY STACK**”.

**⚠ Ensure that all installation work is carried out to professional standards.**

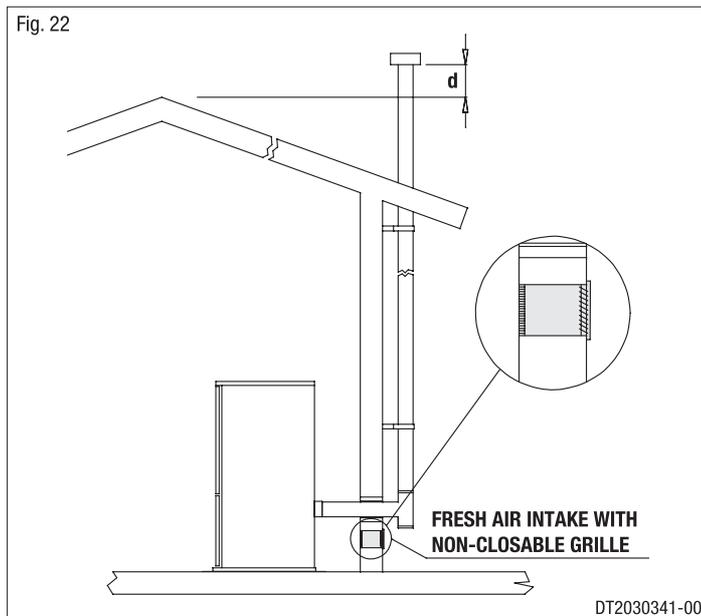

## 1.12 PREVENTION OF DOMESTIC FIRES

The product must be installed and used in compliance with the manufacturer's instructions and European and national standards as well as local regulations.

**⚠ When a flue pipe passes through a wall or a ceiling, special installation methods must be applied (protection, thermal insulation, distances from heat-sensitive materials, etc.) See the paragraph “CONNECTING TO A CONVENTIONAL CHIMNEY”.**

- It is also recommended that all elements made of combustible or inflammable material, such as beams, wooden furniture, curtaining, flammable liquids, etc. be kept outside the heat radiation range of the stove and at a distance of at least 80 cm from the heating block.
- For other information, see the paragraph “**MINIMUM SAFETY DISTANCES**” and “**CONNECTING TO A CONVENTIONAL CHIMNEY**”.
- The flue pipe, chimney stack, chimney and fresh air intake must always be free of obstructions, clean and checked periodically, that is, at least twice during the seasonal period from the lighting of the stove and during its use. When the stove has not been used for some time it is advisable to carry out the checks mentioned above. For further information, consult a chimneysweep.
- Only use recommended fuels (See section “**FUEL**”).