

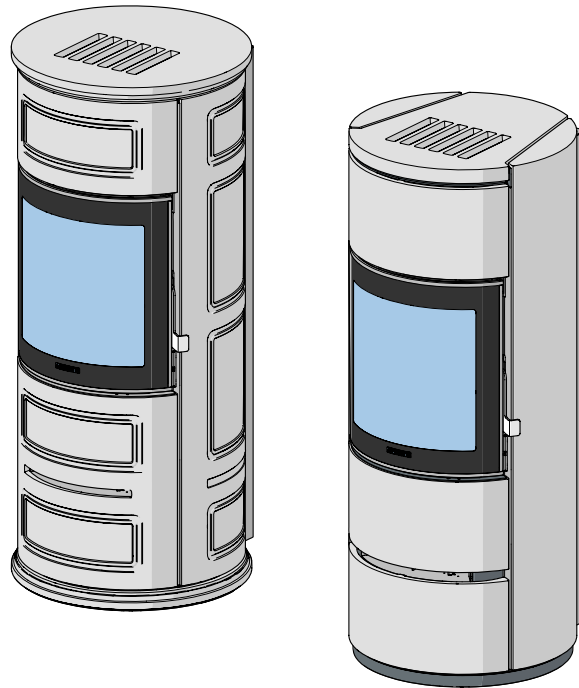

Pellet Stove P943



PRODUCT INFORMATION,
INSTALLATION AND MAINTENANCE



Dear Customer,

We thank you for having chosen one of our products, the fruit of extensive and continuous research for a superior product in terms of safety, reliability and performance.

In the documentation supplied, you will find all the information and advice you need to use your product as safely and efficiently as possible.



Read the instructions and the information, supplied in all forms together with the product and any accessories, as well as the documentation referred to in this manual carefully, before proceeding with installation, use or any repairs.

- If any problems or doubts should arise, please contact your local dealer or the authorized T.A.C. (authorized technical assistance centre).



This manual contains INFORMATION REGARDING THE PRODUCT, INSTALLATION AND MAINTENANCE.

- For information regarding operation, please refer to the manual "*OPERATING INSTRUCTIONS*".

For the restrictions, limitations and exclusions please refer to the warranty included with the product. In line with its policy of constant product improvement and renewal, the manufacturer may make changes without notice.

The images shown in this manual are for explanatory purposes and at times may not accurately depict the product.

This document is the property of Gruppo Piazzetta S.p.A. and no part of it may be reproduced or disclosed to third parties, whole or in part, without written permission All rights reserved by Gruppo Piazzetta S.p.A..

CONTENTS

1	GENERAL INFORMATION	3	6.4	Combustion air connection	20
2	PRODUCT INFORMATION	4	6.5	Connection to the smoke outlet	20
2.1	Product description	4	6.6	Electrical connections	21
2.2	Part identification	5	7	START-UP AND OPERATING TEST	22
2.3	Safety devices	6	8	CLADDING AND TRIM	22
2.4	Check devices	6	9	USE	22
2.5	Product identification data	7	9.1	Humidifier	22
2.6	Characteristics	7	10	CLEANING AND MAINTENANCE	22
2.7	Accessories upon request	7	10.1	Scheduled maintenance	23
2.8	Technical data	8		<i>Recommended interval</i>	23
2.9	Sizes	9	10.2	Cleaning the ceramic cladding	23
3	FUEL	10	10.3	Cleaning the painted metal parts	24
3.1	Pellet specifications	10	10.4	Opening the door	24
3.2	Information regarding pellet loading	10	10.5	Cleaning the glass	24
4	GENERAL INFORMATION REGARDING THE SYSTEM	11	10.6	Disposal of ash	24
4.1	Installation room	11	10.7	Cleaning the ash tray	24
4.2	Fresh air intake	11	10.8	Cleaning the grate and grate support	24
4.3	Chimney	12	10.9	Cleaning the combustion chamber	25
4.4	Chimney terminal	13	10.10	Cleaning the smoke chamber	25
4.5	Flue pipe	13	10.11	Cleaning the extractor fan	26
5	PREPARATION FOR INSTALLING	15	10.12	Cleaning the room fan	27
5.1	Handling	15	10.13	Cleaning the smoke outlet	27
5.2	Unpacking	15	10.14	Replacing the fuses	28
6	INSTALLATION	16	11	WHEN NOT IN USE	28
6.1	Minimum safety distances	16	12	REFERENCE STANDARDS	29
6.2	Installation kit and accessories	17		<i>European Standards</i>	29
6.3	Multifuoco system	17			

1 GENERAL INFORMATION

Definition: The term **system** indicates the unit consisting of the appliance and all the necessary installations which affect its operation, including air intakes, the entire system for the evacuation of the flue gases (smoke duct, flue, chimney) the area, other sources of heat, installations for the propagation of heat (hot air ducting or plumbing system).

Definition: The term **standards** or **regulations** indicates all applicable European or national legislation, local regulations, particular or conventional requirements arising from joint ownership building regulations, and easement or laws or administrative acts, in force in the country where the appliance is to be installed.

Definition: The term **airtight appliance** refers to an appliance (designed specifically) which takes in the air needed for it to operate correctly from an environment outside the installation room. The term **airtight installation** refers to the installation of these types of appliances in such a way that all the air needed for combustion is taken in from the outside.

- This instruction booklet has been prepared by the manufacturer and is an integral part of the product. In the event of sale or relocation of the product make sure this booklet accompanies it, since the information contained in it is addressed to the purchaser and to anyone involved in the installation, use and maintenance of the product.
- Read the instructions and the information, supplied in all forms together with the product and any accessories, as well as the documentation referred to in this manual carefully, before proceeding with installation, use or any repairs. If any problems or doubts should arise, please contact your local dealer or the authorized T.A.C. (authorized technical assistance centre).
- Gruppo Piazzetta S.p.A. cannot be held liable for situations of risk, defects, damage, product malfunctioning or for damage to objects, people or animals resulting from tampering of the appliance and installation, use and maintenance which does not respect the indications provided by regulations and the manufacturer.
- Any changes to the original parameters which determine product operation may only be carried out by authorised persons from the company and with the values set by the manufacturer. Non-authorized interventions on the product will be considered tampering.

 **Product installation, use and maintenance must be carried out in compliance with the applicable instructions provided by the manufacturer and in compliance with all relevant regulations. Failure to respect the indications supplied and incorrect interventions may cause situations of risk, health related problems or product faults.**

- **Product installation and maintenance must be carried out exclusively by qualified personnel with sufficient knowledge of the product itself.**
- **In the event of a malfunction or fault, before carrying out any intervention and before discontinuing product use, please refer to the manual provided by the manufacturer in the sections "FAULTS" or "MESSAGES - SAFETY WARNINGS - ANOMALIES".**

 **In the event of fire in the flue, stop using the appliance, do not open the door of the appliance, observe all safety recommendations and contact the appropriate authorities.**

- **For appliances which are powered electrically, do not disconnect the power supply if unburned smoke/gas forms inside the firebox. Move away and adopt all necessary safety precautions.**
- **Product use may cause some surfaces to become extremely hot (the glass, the external surfaces, the handles, the smoke outlet passage). Only touch these parts during operation if wearing the correct protective clothing or with suitable means.**
- **Since the glass becomes hot, make sure that no person other than those experienced in operating the appliance remain in the area from where the heat emanates.**

 **This appliance is not for use by persons (including children) with reduced physical, sensory, mental capacity or with a lack of experience and knowledge, unless they are helped or have been instructed on how to use the appliance by the person who is responsible for their safety.**

- **During the operation and/or cooling phase, slight creaking noises may be heard. This is not considered a defect, but is a consequence of the thermal expansion of the materials used.**

 **Do not stand or place objects which are not heat-resistant within the prescribed minimum safety distance.**

- **Do not install the product near walls or objects in heat-sensitive or flammable material (wood or similar). It is important to observe and respect the distances and safety indications prescribed by regulations and indicated in the manual provided by the manufacturer in the section "INSTALLATION".**
- **It is forbidden to use the appliance without suitable cladding.**

 **Do not introduce liquid fuel into the appliance, even if this is to burn embers which are already present.**

- **Only power the appliance with fuel which has the characteristics as indicated in the section "FUEL".**
- **Do not use the appliance as an incinerator or in any way other than that for which it was designed.**
- **Do not open the door during operation, or operate the appliance if the glass is broken. When using wood fired appliances, it is only permitted to open the door for the time needed to reload the fuel and in the manner indicated in the section "OPENING THE DOOR".**

Before carrying out any assembly, installation or ignition procedures, the enabled installer must check that the system has been manufactured in compliance with the applicable instructions provided by the manufacturer and in compliance with all relevant regulations. In particular, check:

- suitability of the room where the appliance is to be installed as well as any restrictions
- the existence of any other appliances
- fresh air intake
- ventilation within the area where the appliance is to be installed
- smoke evacuation system comprising a flue pipe, flue and chimney.

Installation may also include a series of operations to be carried out correctly by enabled personnel and for which system compatibility must be guaranteed:

- connection to the air intake
- connection to the smoke evacuation system
- ventilation
- assembly and installation
- any necessary electrical or plumbing connections
- insulation
- start-up and operating tests, and where necessary calibration and adjustment
- cladding and trims
- presentation of additional documentation as prescribed by the regulations
- checking and maintenance.

Other requirements for compliance may be necessary in relation to specifications required by the appropriate Authorities.

2 PRODUCT INFORMATION

2.1 PRODUCT DESCRIPTION

Piazzetta products, always at the forefront and in line with the most stringent requirements in terms of thermal power and environmental protection, are a highly functional solution for heating with exceptional aesthetic characteristics.

This appliance is a heat generator designed to be used with pellets as the fuel source.

The use of a fuel which can be easily transported and stored such as pellets, facilitates the ease of use of this appliance.

The cladding, made of hand-crafted tiles, stores the heat generated by the large radiating surfaces of the steel firebox, which is then gradually and evenly distributed into the environment.

In this way, air quality is not compromised but maintains the correct level of humidity.

The temperatures, which do not reach excessive levels, together with the humidifier increase safety of use and give the feeling of a comfortable, diffused warmth.

Heat diffusion is also ensured by the Multifuoco System forced ventilation system offering different personalised functions and the option of ducting. For example, it is possible to separately manage the settings and heating for the day-time living area and night-time sleeping areas of the home.

A remote control with an LCD screen allows the user to manage and control a range of functions and programmes while the basic controls can also be managed using the control panel on the product itself.

A sensor will warn the user when the level of pellets in the hopper falls below the minimum level allowed.

The pellets are loaded into the hopper manually and the ignition is electronic.

An electronic control unit controls the pellet dosing into the grate as well as the flue gas expulsion.

This control unit oversees the correct operation of the appliance and, thanks to a series of safety devices, signals any faults on the remote control screen and, if necessary, initiates the appropriate procedures.

2.2 PART IDENTIFICATION

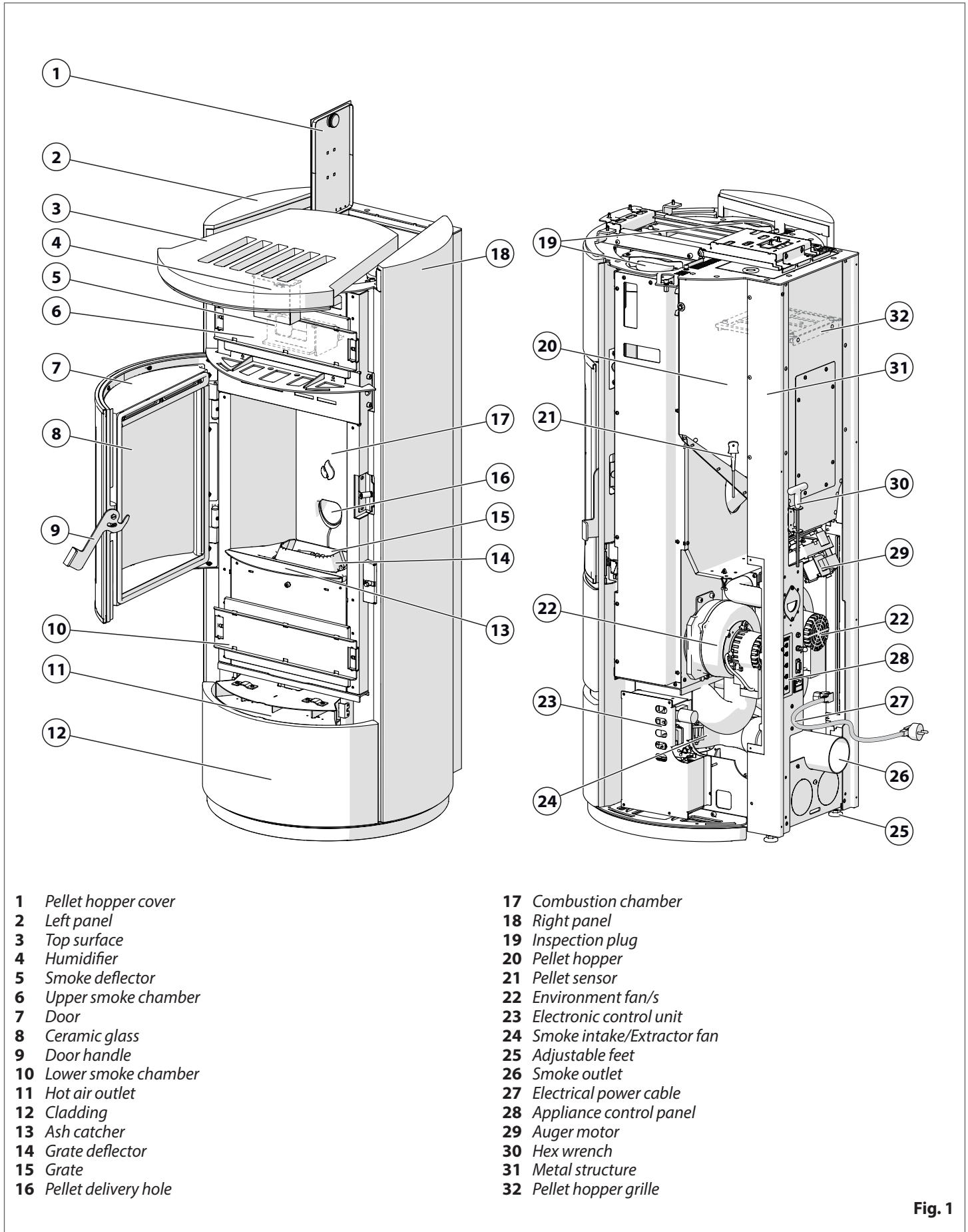

Fig. 1

2.3 SAFETY DEVICES

The appliance is equipped with the following safety and check devices which stop the stove from operating if any faults occur.

Pressure switch:

this is connected to the smoke flue and controls the vacuum inside the flue itself. The pressure switch is activated if the flue evacuation conditions are altered (poor installation, obstacles or impediments in the flue, lack of maintenance, adverse weather conditions such as persistent wind etc..). The pressure switch activates and isolates the supply voltage to the auger, thus stopping pellet feed to the grate and then initiates the appliance shut down process.

Hopper thermostatic probe:

this is a thermostatic probe which automatically rearms and is located on the pellet hopper. It serves to safeguard the hopper against excessive thermal excursions.

If the temperature of the hopper exceeds the safety threshold, the thermostat isolates the supply voltage to the auger, pellet feed to the grate is stopped and the appliance shut down procedure begins.

Smoke temperature probe:

this is connected to the electronic board and constantly monitors the operating temperature. If during this phase the smoke temperature:

- a) *exceeds the safety threshold, the electronic control unit isolates the supply voltage to the auger, thus stopping pellet feed to the grate and starting the appliance shut down process*
- b) *falls below the minimum operating temperature, the appliance stops and an acoustic alarm signal is activated.*

Furthermore, if during the start-up phase a system malfunction is detected, an acoustic alarm signal is activated.

Auger safety:

auger operation is constantly monitored by the electronic board. If there is a malfunction which produces a continuous discharge of the pellet, an acoustic alarm signal is activated. The electronic control unit isolates the supply voltage to the auger, thus stopping pellet feed to the grate and starting the appliance shut down process.

Extractor fan safety:

the rotation of the extractor fan is constantly monitored by the electronic board. In the event of a fan malfunction, an acoustic alarm signal is activated. The electronic control unit isolates the supply voltage to the auger, thus stopping pellet feed to the grate and starting the appliance shut down process.

Electrical safety:

the appliance is protected by fuses in the event of a power surge.

Firebox door opening sensor:

if the firebox door is opened during operation, an acoustic alarm signal is activated. The electronic control unit isolates the supply voltage to the auger, thus stopping pellet feed to the grate and starting the appliance shut down process.

Electronic control unit:

the electronic control unit signals and controls a series of events including power and ignition failure.



The safety devices have the task of eliminating any risk of damage or injury to persons, animals or objects. IT IS FORBIDDEN to tamper with the safety devices or allow any intervention to be carried out by non-qualified personnel.

2.4 CHECK DEVICES

The appliance is equipped with some check devices which are to be used exclusively by personnel authorised to carry out fine tuning operations during installation and maintenance procedures.

Pressure plug (A): to measure the smoke outlet pipe vacuum.

DB9 serial port (B): to carry out checks on the correct operation of the product and any necessary maintenance operations. The GPRS kit (optional) may be connected to the DB9 serial port.

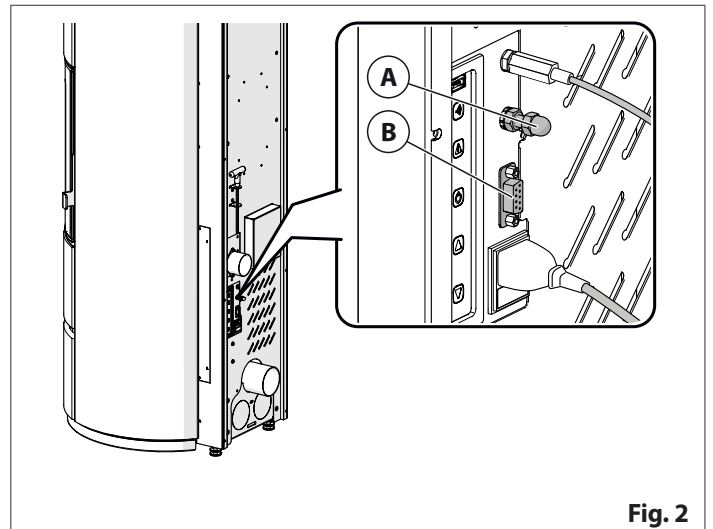

Fig. 2

2.5 PRODUCT IDENTIFICATION DATA

Each product is identified in the following way:

- **IDENTIFICATION DATA PLATE** (1) with the model (A) and appliance performance specifications
- **SERIAL NUMBER PLATE** (2) with the serial number of the appliance (B)
- **LABEL WITH IMPORTANT ADDITIONAL INFORMATION** (3) with important information.

The identification plates are positioned as shown below.

i Always provide this information when requesting service and/or spare parts from the dealer or Technical Assistance Centre.

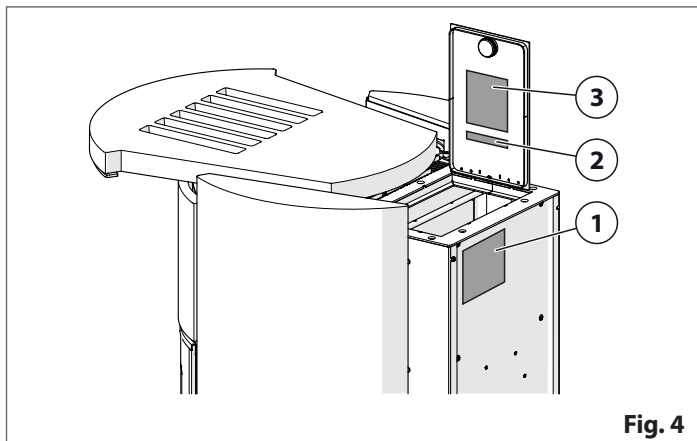
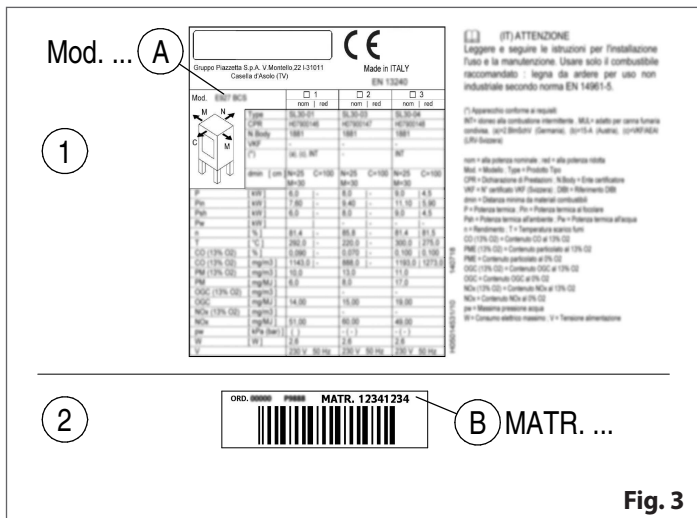

2.6 CHARACTERISTICS

Cladding:

- tiles

Structure:

- in steel

Firebox:

- in steel
- in Aluker

Grate:

- in cast iron

Door:

- in cast iron
- ceramic glass resistant to 750°C

Door handle:

- in steel
- nickel plated finish

Function control:

- appliance control panel
- LCD remote control device

Power adjustment:

- 5 positions

Heating:

- forced ventilation with Multifuoco System
- 2 fans
- 4 speed settings

Hot air ducting:

- maximum permitted length approximately 16 m
- outlet diameter Ø 7.5 cm

Provided as standard:

- room temperature probe
- Schuko cable IEC (L=200)
- humidifier (in stainless steel)
- silicon spray paint
- spray bottle
- hex wrench 5 mm
- Easy Cleaning System (ash vac)

2.7 ACCESSORIES UPON REQUEST

- Flue connection pipes and bends
- Combustion air kit
- Floor protection
- GPRS module for appliance remote control.

2.8 TECHNICAL DATA

Description	Model	P943		P943	
	Product type	SP230-01		SP230-03	
	Unit of measurement	at nominal heat output	at reduced heat output	at nominal heat output	at reduced heat output
Fuel		natural pure wood pellets		natural pure wood pellets	
Heat output	kW	10,3	3,6	12,5	3,6
Hourly fuel consumption	kg/h	2,228	0,793	2,753	0,793
Efficiency	%	94,1	91,8	92,1	91,8

CONTENT OF SMOKE EMISSIONS

CO (at 13% of O ₂)	%	0,010	0,049	0,009	0,049
	mg/Nm ³	127,2	611,6	116,7	611,6
Dust (at 13% of O ₂)	mg/Nm ³	19,9	26,0	26,8	26,0
Dust (at 0% of O ₂)	mg/MJ	12,9	16,9	17,4	16,9
OGC (at 0% of O ₂)	mg/MJ	3,00	9,60	5,80	9,60
NO _x (at 0% of O ₂)	mg/MJ	81,60	94,60	80,00	94,60

ELECTRICAL DATA

Maximum power draw	W	500,0	500,0
Absorbed power in operation	W	150	150
Rated Voltage	V	230	230
Rated Frequency	Hz	50	50

PHYSICAL DATA

Approximate hopper capacity	kg	20	20
	l	32	32
Smoke outlet diameter	cm	8	8
Weight of appliance with cladding	kg	180	180

AIR FLOW

Fresh air intake (minimum useful section)	cm ²	100	100
---	-----------------	-----	-----

CERTIFICATION DATA

Test report	N°	K 1595 2015 T1	K 1595 2015 T1
Notified laboratory	N°	2456	2456
Declaration of performance	N°	-	-

TECHNICAL DATA FOR FLUE CALCULATIONS

Smoke flow	g/s	6,70	5,30	7,80	5,30
Average temp. smoke in gas outlet pipe	°C	114,8	82,6	153,3	82,6
Minimum draught	Pa	12	10	12	10

SAFETY DISTANCES (refer to the section "MINIMUM SAFETY DISTANCES")

A	Product air distance from the rear non-flammable wall	cm	5	5
	Product air distance from the rear inflammable wall	cm	15	15
B	Product air distance from the side walls or insulating material	cm	20	20
C	Area clear of flammable objects	cm	80	80
D	Distance of front floor protection overhang	cm	50	50
E	Distance between inside edge of firebox opening and the edge of the floor protection	cm	30	30
H	Distance clear from top edge of product	cm	40	40

Data taken from laboratory tests using pellets with a thermal capacity of 5 kWh/kg.

The above data may vary in relation to the size and type of fuel used (refer to the section "FUEL"), chimney vacuum and system characteristics.

Suitable for shared flue chimney (if permitted by national regulations and local laws).

Data regarding the electric absorption vary depending on the network voltage and any KITS or ACCESSORIES which have been installed. Refer to the instructions attached to the Kits or accessories.

2.9 SIZES

(values in cm)

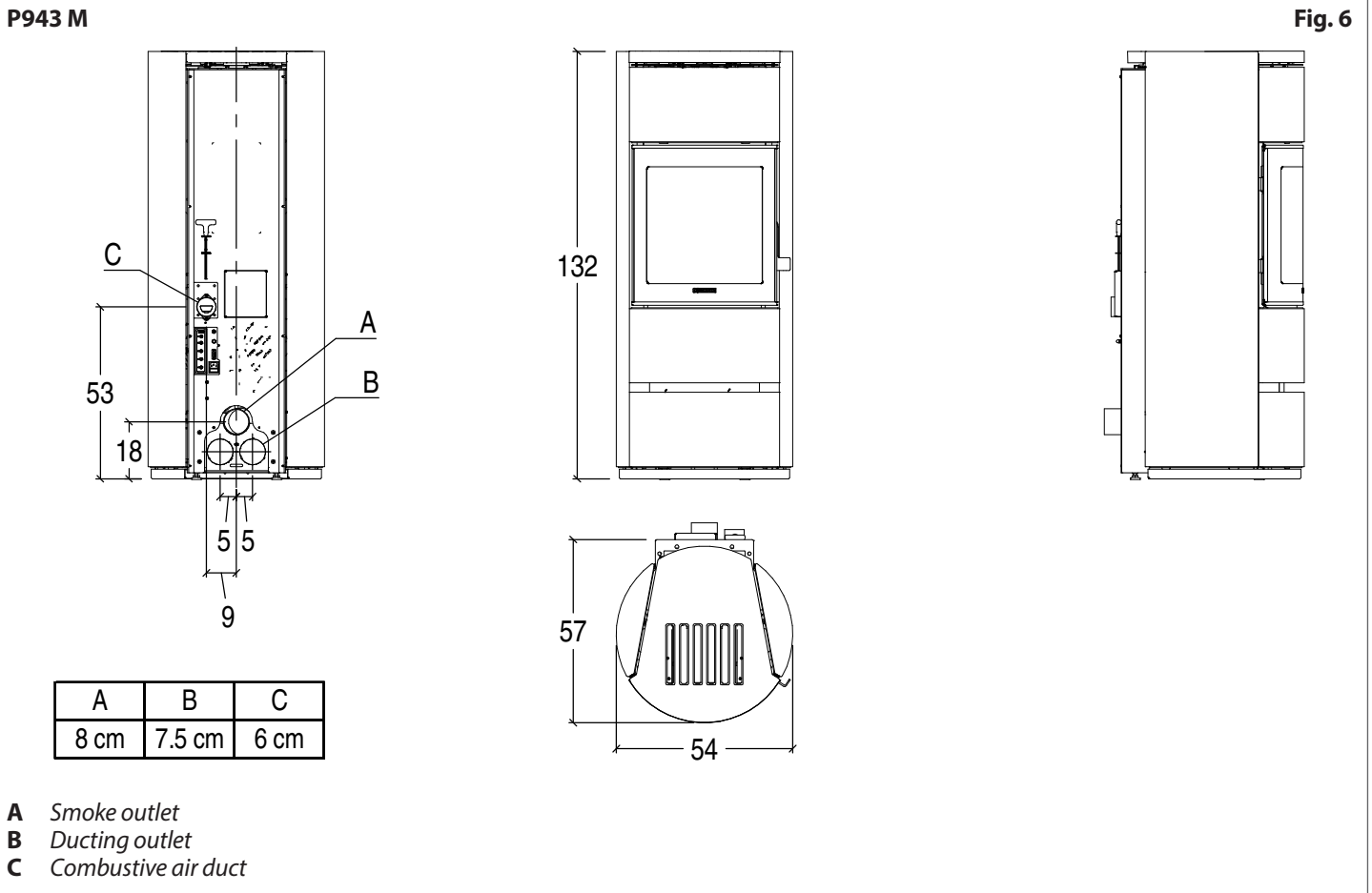
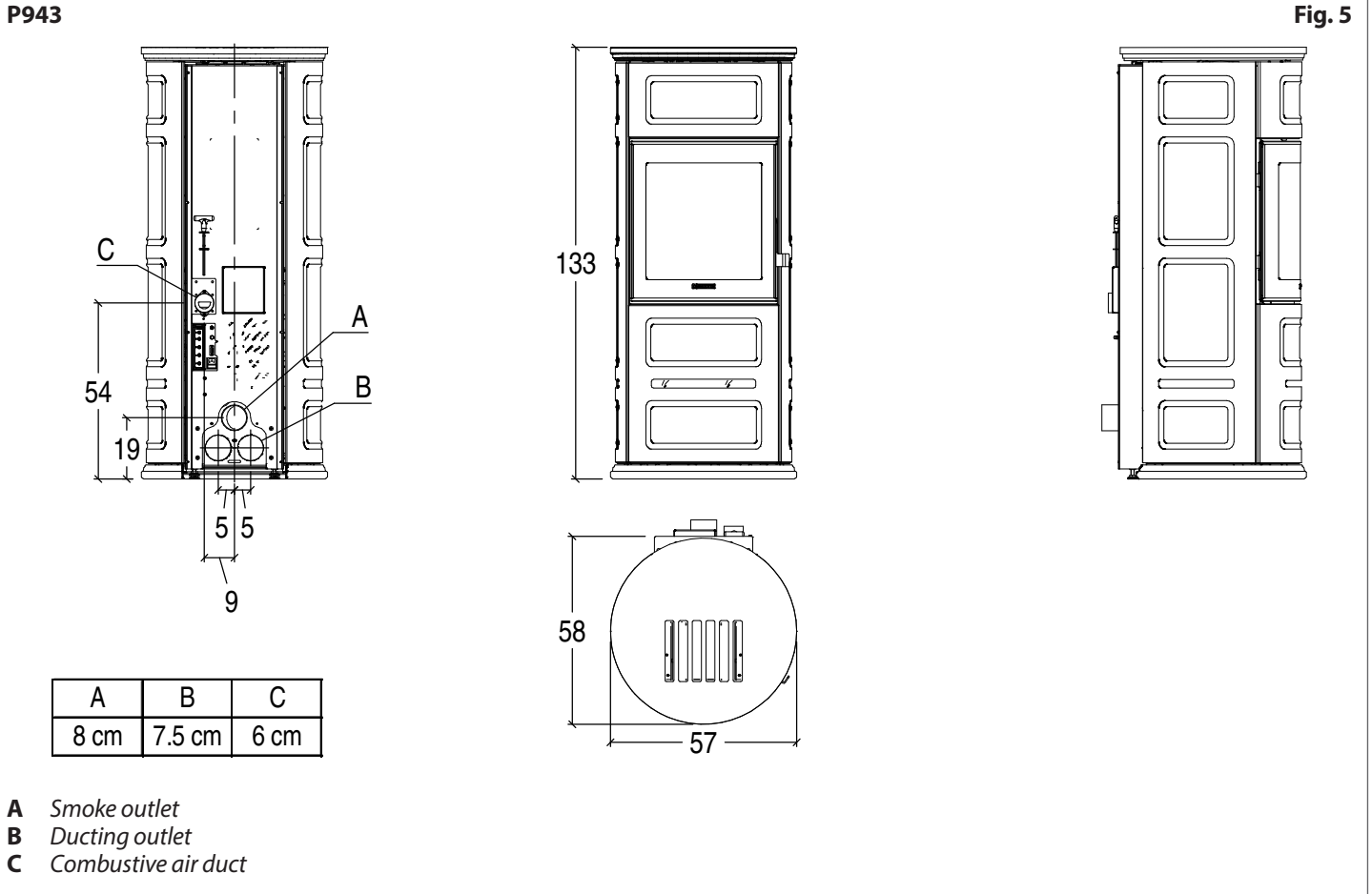

3 FUEL

3.1 PELLET SPECIFICATIONS

 Under no circumstances use fuel other than pellets.

There are various types of pellet on the market with qualities and characteristics that vary depending on the processes they have undergone and the type of wood used in their production. Since the characteristics and quality of the pellet considerably affect product performance, efficiency and proper operation, we recommend that you use high-quality pellets. In order to guarantee efficient product operation, Gruppo Piazzetta S.p.A. has tested and programmed its own products with pellets with the characteristics as shown in the table.

Pellet specifications	
Parts	Natural pure wood pellet
Length, approx.	10 - 30 mm
Diameter, approx	6- 6,5 mm
Apparent density, approx.	650 kg/m ³
Specific weight, approx.	>1,0 kg/dm ³
Net heat value, approx.	5 kWh/kg
Moisture content, approx.	< 8 %
Residual ash, approx.	< 0,5 %
Note: : the above data refer to beech/fir wood pellets	

 **DO NOT** use pellets with dimensions other than those recommended by the manufacturer.

- **DO NOT** use pellets containing sawdust, bark, maize, resins or chemical substances, additives or adhesives.
- **DO NOT** use damp pellets.

Choosing other unsuitable pellets may:

- obstruct the grate and flue gas pipe
- increase fuel consumption yet reduce performance
- mean that proper stove operation cannot be guaranteed
- cause dirt to build up on the glass
- leave particles which have failed to burn and heavy cinders.

The presence of moisture in the pellets increases their volume and causes them to split which in turn causes:

- malfunction of the fuel-loading system
- inefficient combustion.

Pellets should be stored in a sheltered, dry place.

- When using good quality pellets but with dimensions and heat-producing properties other than those recommended above, it is necessary to change the stove operating parameters.

 This "customisation" of appliance operating settings must only be carried out by a T.A.C. (technical assistance centre) or by specially qualified personnel authorised by Gruppo Piazzetta S.p.A..

- Using pellets that are out of date or not in conformity with the manufacturer's recommendations not only damages the stove and jeopardises its performance, but can render the guarantee null and void and relieves the manufacturer of all liability.

3.2 INFORMATION REGARDING PELLET LOADING

In order to load pellets into the hopper, we recommend removing the bag flap opening and emptying it into the hopper. This way, the loading operation is easier and you avoid spilling the pellets over the appliance.

 Do not allow the build-up of residue at the bottom of the hopper.

- Do not empty any residue from the pellet bag into the hopper.
- During loading operations, make sure that no pellets fall out of the hopper as they could come into contact with hot surfaces and ignite.

 Some appliances are equipped with a protection grille inside the hopper. Removing this grille is forbidden.

- Only keep the cover of the pellet hopper open for as long as it takes to complete the refill operation. To ensure optimal operation, some models activate an error signal in the event the hopper cover is left open for a time exceeding the set time.

4 GENERAL INFORMATION REGARDING THE SYSTEM

Below is some general information regarding the system, appliance installation and products manufactured by Gruppo Piazzetta S.p.A.

 Please refer to the installation standards or other informative documentation provided by the manufacturer for further information.

4.1 INSTALLATION ROOM

The appliance is to be installed in a room which allows installation, user and maintenance operations to be performed safely and easily.

If the product being installed requires a power socket, the room must also be provided with an earthed power supply in accordance with current regulations.

 Appropriate ventilation in the installation room must be ensured (refer to the section "*FRESH AIR INTAKE*").

- The installation room and the area which is to be heated must be suitable sized and have appropriate characteristics in relation to the heating capacity of the appliance. Compare the information provided in the section "*TECHNICAL DATA*" with the power required by the area which is to be heated.
- If the room or the product installation area (technical room, perimeter walls, recess, supporting walls, etc.) are not suitably insulated, the heating capacity of the appliance will be reduced.
- Consult a heating technician or engineer for a correct check and calculation of the requirement of the environments to be heated and the corresponding regulations.

 Make sure that the floor of the installation room is able to withstand the weight of the product including any cladding, accessories and trim. If the floor does not have a suitable load-bearing capacity, take adequate counter-measures.

 The existence of more than one appliance is only permitted if allowed by the regulations and manufacturer of each individual appliance.

- If the existence of more than one appliance is permitted, all regulations and provisions supplied by the manufacturer of each individual appliance are to be respected.
- C type gas appliances (please refer to legislation in force) are permitted in the installation room of the appliance.

 The installation room must not be used to store flammable material.

Further limitations for NON airtight installations and installations which do not have combustion air intake from outside

 Installation room:

- must not be a stairwell (unless the building has a maximum of two rooms), a hallway or a room with a volume of less than 15m³
- must not be a bedroom, a bathroom, a shower room or a studio flat with the exception of airtight installation or the installation of an appliance with a closed firebox with combustion air drawn and ducted directly from outside
- must not have a low pressure compared to the exterior due to a counter draught caused by the presence of another appliance or extractor device in the room where the appliance is installed (eg. forced ventilation systems or other heating systems using ventilation to change the air).

 In the appliance installation room:

- it is not permitted to install liquid fuel appliances with continuous or discontinuous functioning which draw combustion air from the room where the appliance is installed
- simultaneous use of more than one appliance (two stoves or a fireplace and a stove, etc.) is not permitted unless:
 - all provisions indicated by the manufacture of each individual appliance have been respected
 - in situations of heavy use simultaneous operation, the vacuum measured between the internal and external environment is greater than the value determined by regulations (4 Pa).
- Type B gas appliances used for heating the room, with or without the production of domestic hot water are not allowed
- devices suitable for cooking food with relative hoods without an extractor fan may only be used in kitchens.

4.2 FRESH AIR INTAKE

In order to operate normally, each appliance must be provided with the air needed for combustion.

If a number of appliances are to co-exist, sufficient airflow must be guaranteed for each individual product in full compliance with regulations and according to the manufacturer's indications.

For a question of health, in addition to providing the air flow needed for combustion, it is also recommended that the air inside the installation room is suitably changed.

The airflow needed for the firebox can be obtained in different ways, for example:

- from the installation room or adjacent rooms
- by means of a fresh air intake directly into the room and with ducting
- with a direct connection to the combustion chamber.

In brief, the fresh air intake:

- must have a total free cross section of at least the value indicated in the section "TECHNICAL DATA" and in any case, equal to or greater than the section of the air intake on the appliance
- be protected by a grille or suitable protection which does not reduce the recommended minimum section
- be positioned in such a way that it is not obstructed and maintenance and inspection operations are possible.

Indications for airtight installations and installations with combustion air intake directly from the outside

Airtight installations must be carried out by connecting the combustion air inlet of the appliance directly to the fresh air intake using a connecting pipe.

The connecting pipe for the combustion air inlet of the appliance must comply with the following requirements:

- have a diameter equal to or greater than the diameter of the inlet on the appliance
- be of a suitable, non-flammable material
- the pipes, the connectors used and the installation methods must guarantee an airtight seal
- if they are connected directly to the outside, the inlet must prevent atmospheric conditions from negatively affecting the combustion, for example, by means of the installation of a 90° bend at the inlet facing downwards or a shatter-proof guard
- If the installation requires a connection to coaxial type pipes with the inlet of pre-heated combustion air, the materials used must adequately resist the operating temperature.

For the product to operate correctly, the ducting must have the characteristics specified in the section "COMBUSTION AIR CONNECTION".

4.3 CHIMNEY

Every appliance must be connected to a chimney in order to discharge the combustion gases outside via natural draught.

In brief, remember that the chimney:

- must be in compliance with regulations, equipped with CE marking and be made respecting all safety requirements
- must be suitable for the specific operating conditions of the appliance to be installed and appropriately sized in relation to the appliance; in particular, it must guarantee the minimum draught specified by the appliance manufacturer

- must be attached to one individual appliance, whether that be a stove, a wood-burning stove or an extraction hood unless otherwise specified in the section "TECHNICAL DATA".

It is recommended that the chimney has a chamber for collecting solid matter and any condensate below the connection and which may be easily opened and inspected by means of an air tight door

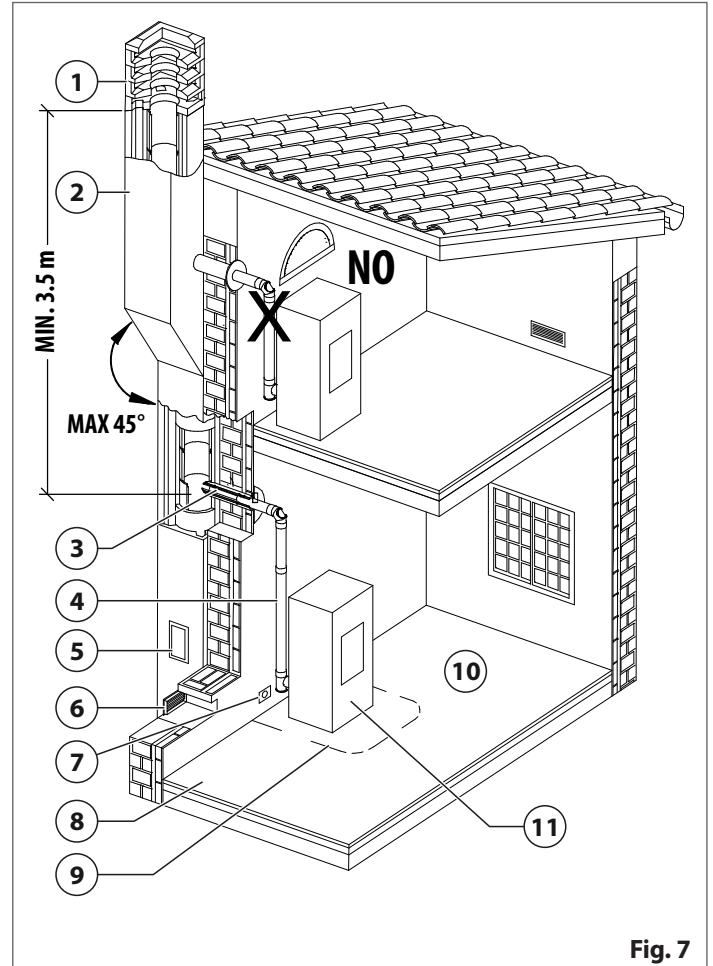

Fig. 7

- 1 Chimney terminal
- 2 Flue
- 3 Connection to the flue
- 4 Flue pipe
- 5 Soot inspection
- 6 Fresh air intake
- 7 Electrical supply
- 8 Check the load bearing capacity of the floor
- 9 Minimum safety distances
- 10 Installation environment
- 11 Appliance (Heat generator)

If the chimney does not meet the requirements, consult with specialised personnel regarding adjustment of the current chimney, for example, by providing adequate piping.

- The connection for the combustion product outlet must comply with local regulations.**
 - In other European countries combustion products must be discharged through the roof and it is forbidden to discharge combustion products directly on the wall or towards closed spaces even if in the open air.
 - Please refer to the standards for clarifications on the restrictions and requirements in your area.

4.4 CHIMNEY TERMINAL

The chimney terminal is the part which is positioned on the top of the flue to ease the dispersion of combustion products into the atmosphere.

In brief, remember that the chimney terminal:

- must have a useful outlet section of not less than twice that of the flue
- must be built in such a way as to prevent the penetration of rain, snow and foreign matter into the chimney
- must be constructed in such a way as to ensure that in the event of winds from all directions and angle, discharge of the combustion products is assured (chimney terminal with anti downdraught cowl)
- must be positioned outside the reflux area
- must be positioned taking into account the roof inclination and respect the distances in relation to buildings, plants, aerials or other obstacles as prescribed by regulations.

4.5 FLUE PIPE

Flue pipe indicates the set of components which connect the appliance to the flue.

- Distance (F): for information regarding the safety distances, installation methods, maintenance, safety and insulation, please refer to the indications attached provided by the flue pipe manufacturer.**
 - The minimum distance (F) from heat sensitive construction elements or inflammable materials must be respected along the entire length of the flue pipe (for example, cladding, walls, beams or wooden ceilings, etc.), furthermore, when a pipe passes through a wall or ceiling, particular installation methods must be applied.
 - In order to ensure safety where there may be the risk of accidental contact with the flue pipe, the external surface must be sufficiently protected in compliance with regulations and instructions provided by the flue pipe manufacturer.

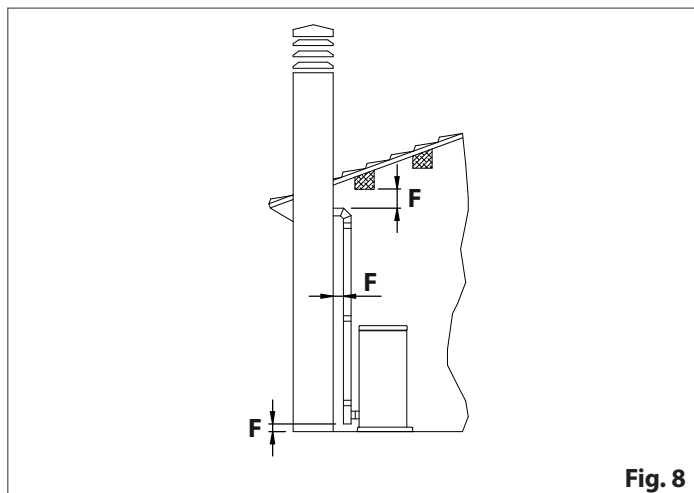

Fig. 8

- The connecting flue pipe must not cross rooms where it is prohibited to install combustion appliances, nor in other rooms divided into compartments for fire or with the hazard of fire, or in rooms and/or spaces that cannot be inspected.**
 - It is forbidden to install hoses or pipes made of metal or fibre cement, pipes which do not have CE approval and the use of elements with reverse slope.
 - In forced ventilation products (for example pellet stoves), it is forbidden to install grates or valves which may obstruct the exhaust smoke passage.

In particular, remember that the flue pipe:

- must be in compliance with regulations, equipped with CE marking and be made respecting all safety requirements
- must be suitable for the specific operating conditions of the appliance to be installed and appropriately sized in relation to the appliance; in particular, it must guarantee the minimum draught specified by the appliance manufacturer
- must be airtight and tight to all combustion products
- must be installed so as to allow normal thermal expansion and be self supporting so as not to inflict its weight on the smoke outlet. If this is not the case, secure it with appropriate supports
- must be secured to the chimney intake so as not to obstruct the exhaust smoke passage; furthermore, the end section of the intake and the chimney axis must intersect
- it is recommended that it is equipped with inspection apertures so that periodic cleaning and maintenance operations can be carried out without the need for completely disassembling the duct
- must have a diameter, along the entire length, no less than that of the appliance outlet.

Additional requirements for the flue pipe

To ensure correct product operation, where not specified under items "TECHNICAL DATA" and "CONNECTION TO THE SMOKE OUTLET", the connection to the flue pipe must have the following characteristics:

length of the flue pipe (a)	maximum 7.5 m
length of the flue pipe projecting horizontally (b)	maximum 4 m
length of the first horizontal section (d) of the flue pipe, connected to the appliance directly or by means of a T connector or elbow connector (*)	maximum 1 m
number of direction changes (c) not greater than 90° including the one relating to the connection of the appliance to the chimney (**)	maximum 3
diameter of flue pipe for appliance with power < 12 kw	minimum 80 mm
diameter of flue pipe for appliance with power > 12 kw	minimum 100 mm

(*) in this case, after the horizontal section (d), there must be a direct insertion of the flue pipe or a vertical section (e) of the flue pipe with a minimum length of 1.5 m.

(**) if the smoke outlet prearranged on the appliance has a horizontal axis, the direction change (t) resulting from the appliance connection (by means of a T connector or an elbow connector) is not counted.

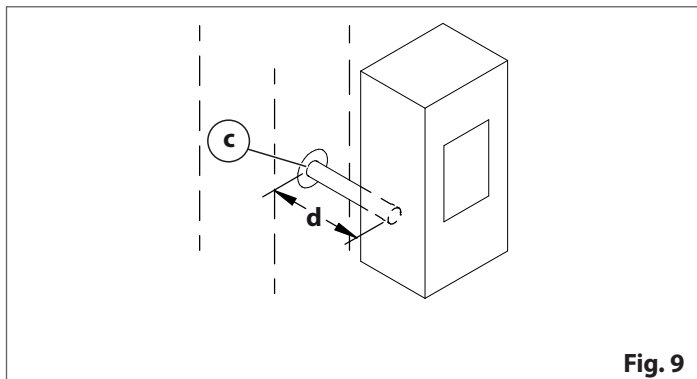

Fig. 9

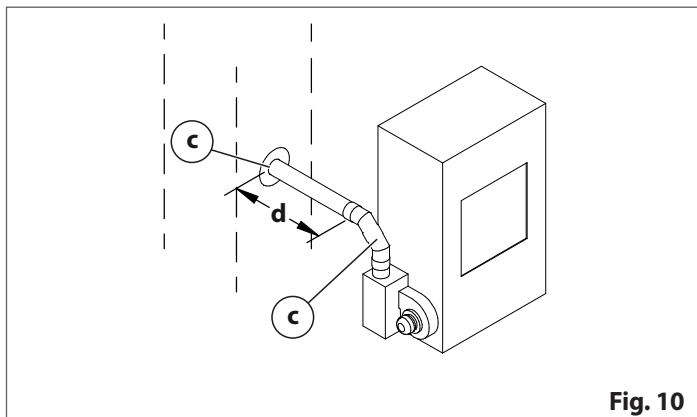

Fig. 10

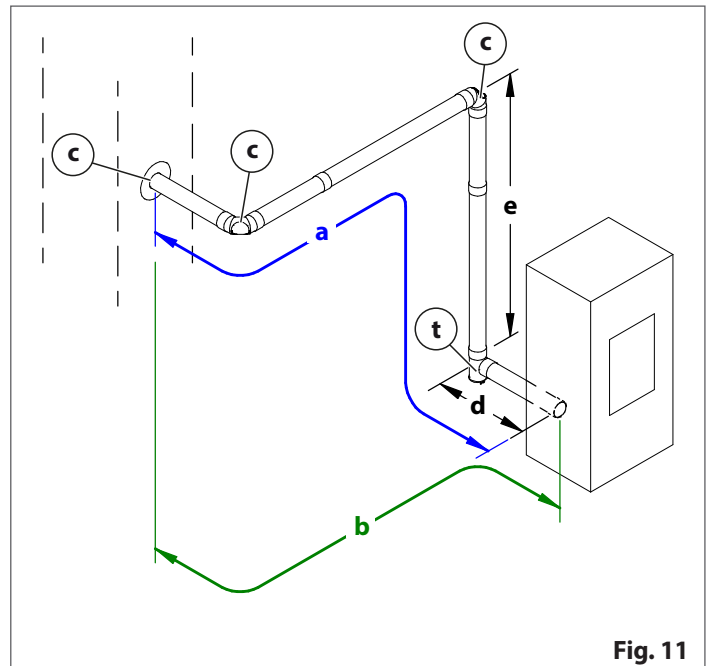

Fig. 11

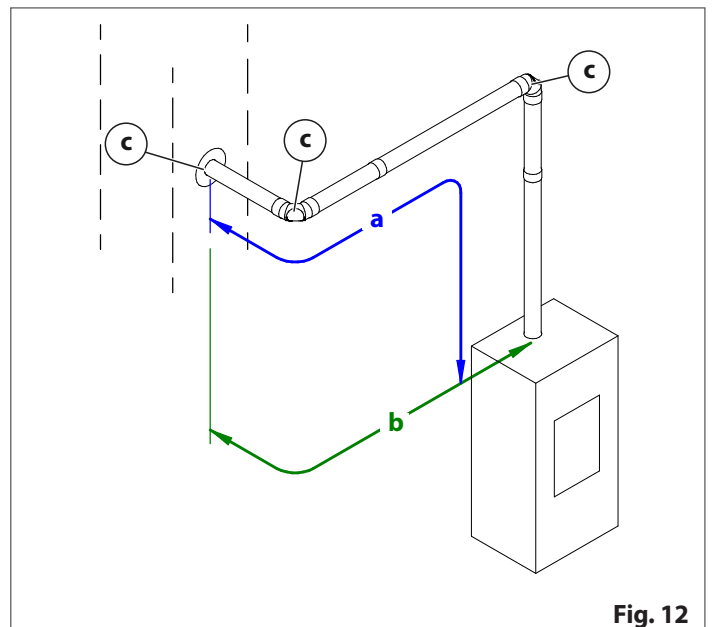

Fig. 12

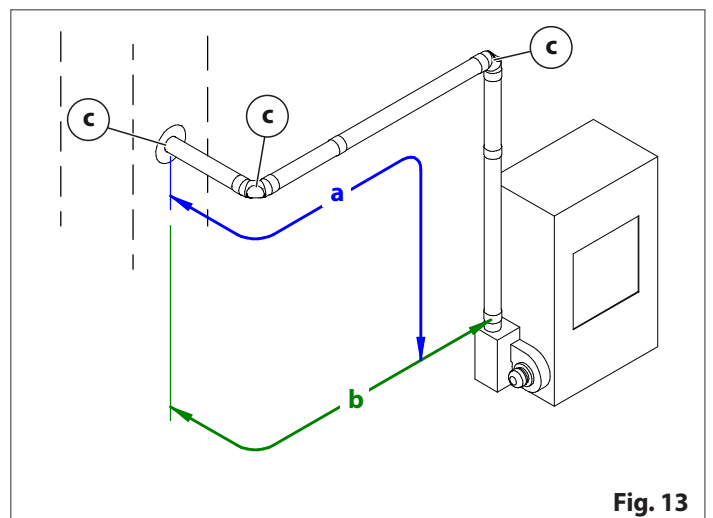

Fig. 13

5 PREPARATION FOR INSTALLING

5.1 HANDLING

In order to prevent any accidents or damage to the product, please follow the recommendations below.

- Unpacking and installation must be carried out by at least two people
- the product must always be moved and handled with suitable equipment in full compliance with current safety regulations
- the packaged product must be kept in the position according to the directions shown by the diagrams and signs on the pack
- if ropes, straps or chains are used, ensure that they are able to take the weight of the pack and that they are in good condition
- use slow continuous movements when moving the pack to avoid jerking the ropes, chains etc.
- do not tilt the package excessively to avoid toppling
- never stand in the vicinity of loading/unloading equipment (forklift trucks, cranes etc.).

When handling any steel parts of the cladding it is advisable to use clean cotton gloves to avoid leaving fingerprints which are difficult to remove at first time of cleaning.

5.2 UNPACKING

! Before beginning installation, make sure all the retainers securing the product to the pallet have been removed.

! When unpacking and removing the packaging material, make sure the product is not scratched or damaged.

- Do not leave parts of the packaging where they are within the reach of children as they could be dangerous. Dispose of them according to legislations currently in force.
- Remove the accessories' packaging and any pieces of polystyrene or cardboard used to secure removable parts, etc. from the firebox and hopper.

After having removed the material protecting the appliance, remove all the retainers securing the appliance to the pallet and then remove it from the pallet.

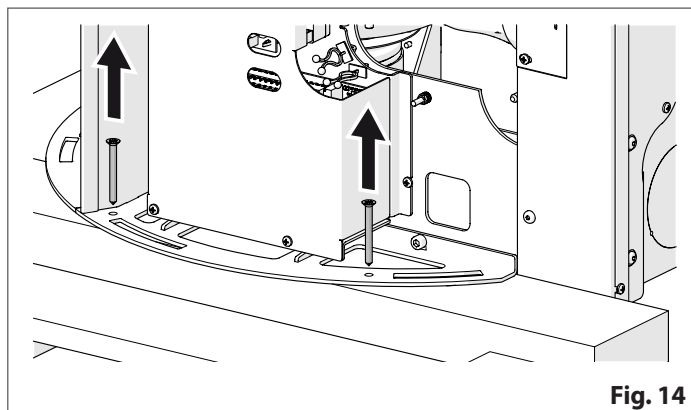

Fig. 14

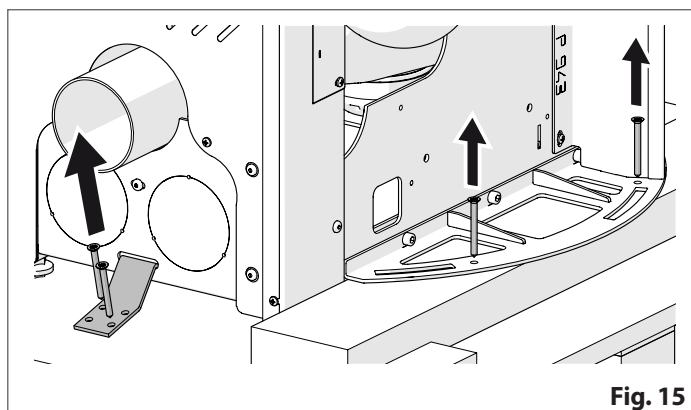

Fig. 15

Releasing the sliding cover

Once the appliance positioning operations have been completed, remove the screws (1) securing the sliding cover. The designated wrench is supplied for the screws.

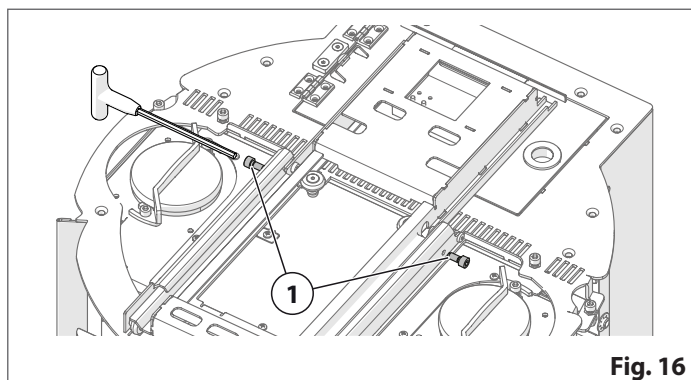

Fig. 16

Remove the fastening screws (2) to release the humidifier.

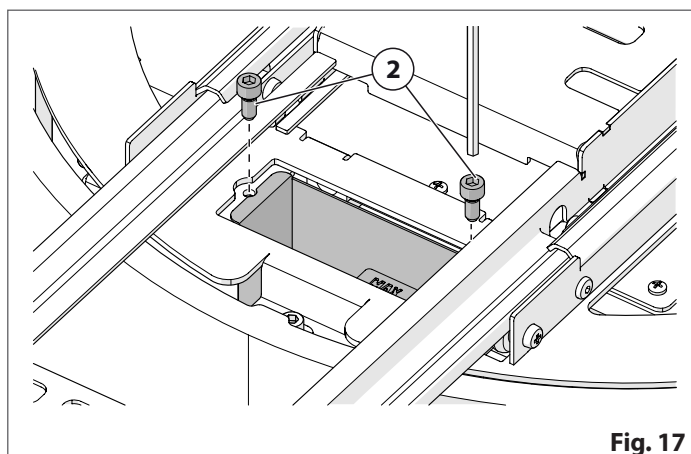

Fig. 17

Positioning the smoke deflector

After having completed the appliance positioning operations and before starting it:

- remove the fastening screws (1) of the upper smoke chamber cover (2)

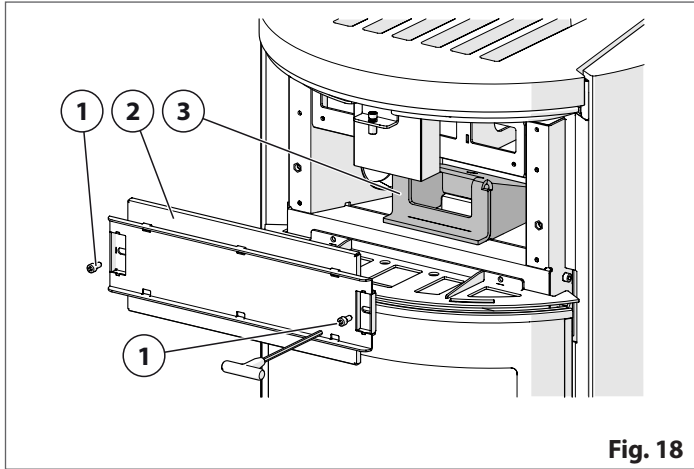

Fig. 18

- position the smoke deflector (3) found in the accessory pack into its seat

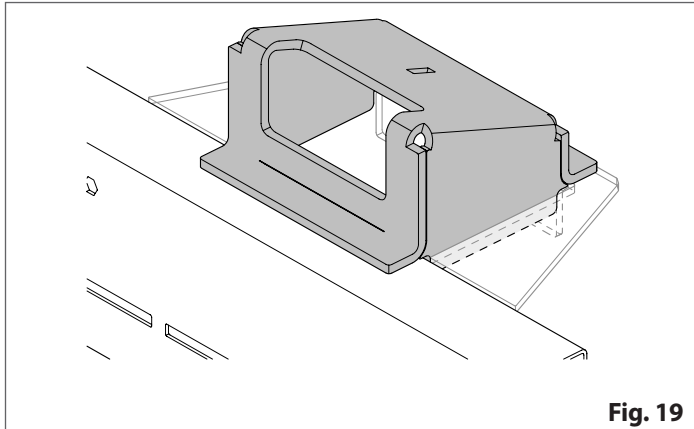

Fig. 19

- close the smoke chamber cover (2) again making sure that it is correctly sealed.

The designated wrench is supplied for the screws.

Positioning the grate deflector

After having completed the appliance positioning operations and before starting it:

- open the firebox door
- position the grate deflector (1) above the grate (3) inserting the tabs (2) in the reference points on the grate

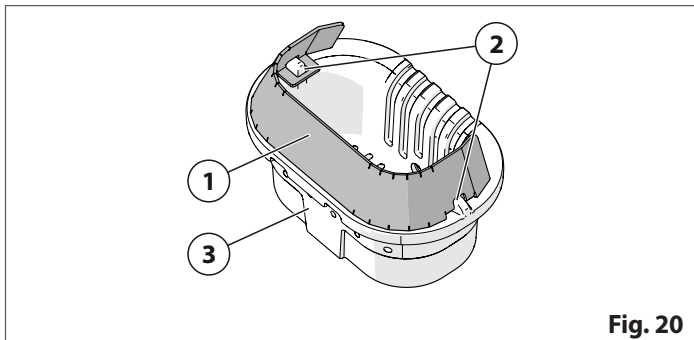

Fig. 20

6 INSTALLATION

6.1 MINIMUM SAFETY DISTANCES

The position of the product inside the room must take into account not only the regulations, heating requirements, the shape of the installation and adjoining rooms but also accessibility during installation, use and maintenance operations.

It is therefore recommended that an area greater than the one indicated, is left around the appliance to facilitate maintenance interventions and prevent overheating problems.

The walls adjacent to the product, the structure above the appliance and the floor on which the appliance rests must be in non-flammable material.

Installation is allowed near heat sensitive or flammable objects as long as there is suitable insulation protection and distances are respected (for example, in the case of a wooden floor, a protective base must be used).

Construction elements which are already present such as wooden beams or a counter-hood and all trims in combustible material must be positioned outside the irradiating range of the product and away from any grilles or slits from which hot air is released. Suitable insulating material must be used.



The product must be installed in compliance with the appropriate safety distances from the walls and objects. Failure to comply with these indications could result in fire.



Keep any flammable products such as: wood furniture, carpets, curtains, flammable liquids, etc.. well away from the product during operation (please refer to distance C).



Please refer to the section "TECHNICAL DATA" and installation instructions for the values.

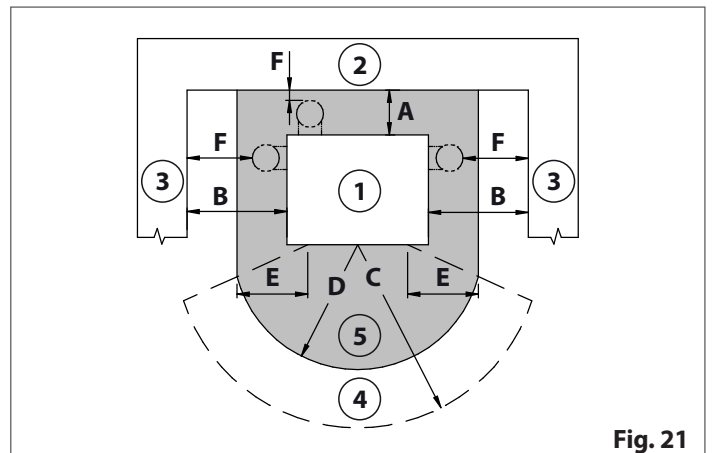

Fig. 21

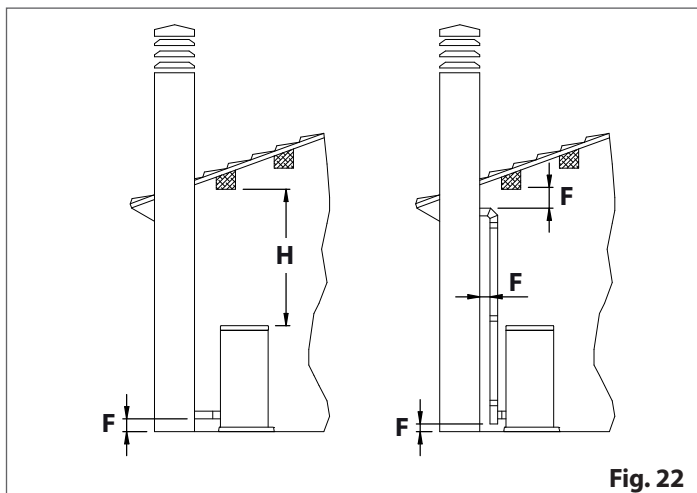

Fig. 22

- 1 Appliance (heat generator)
- 2 Rear wall
- 3 Side wall
- 4 Radiant area of the fireside opening
- 5 Floor protection
- A Product air distance from rear wall
- B Product air distance from side walls
- C Area clear of flammable objects
- D Distance of front floor protection overhang
- E Distance between inside edge of firebox opening and the edge of the floor protection
- F Air distance of the flue pipe from the other elements
- H Distance clear from top edge of product

! Distance (F): for information regarding the safety distances, installation methods, maintenance, safety and insulation, please refer to the indications attached provided by the flue pipe manufacturer.

- The minimum distance (F) from heat sensitive construction elements or inflammable materials must be respected along the entire length of the flue pipe (for example, cladding, walls, beams or wooden ceilings, etc.), furthermore, when a pipe passes through a wall or ceiling, particular installation methods must be applied.
- In order to ensure safety where there may be the risk of accidental contact with the flue pipe, the external surface must be sufficiently protected in compliance with regulations and instructions provided by the flue pipe manufacturer.

6.2 INSTALLATION KIT AND ACCESSORIES

i For the installation of any KITS and ACCESSORIES, please refer to the instructions provided with the kits or accessories.

6.3 MULTIFUOCO SYSTEM

“Multifuoco System” is a system for channelling hot ventilated air into a designated room.

In this EXCLUSIVE system PATENTED by Gruppo Piazzetta S.p.A., heat produced by the firebox is distributed from bottom-up within the room by means of one or more than one fan.

This solution has the significant advantage of even temperature distribution.

6.3.1 Hot air outlet provision

The appliance is supplied as standard with the hot air outlet through the opening (A).

To deflect the air flow in the desired direction, simply adjust the angle of the deflectors (B) (one, or more than one depending on the model, please see the figure).

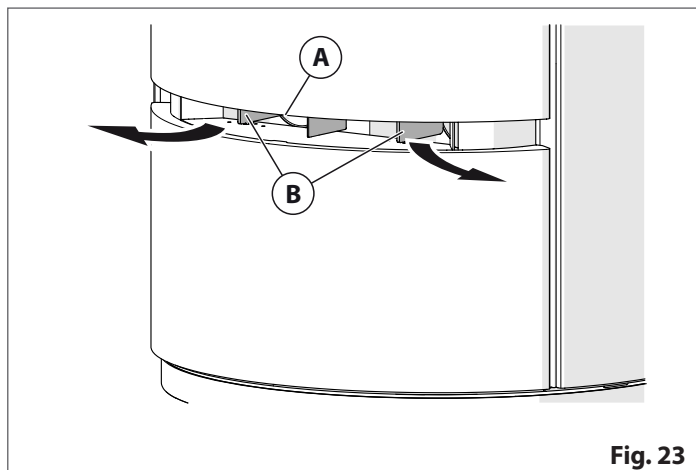

Fig. 23

6.3.2 Hot air outlet in other directions

During installation, it is possible to divert and duct the hot air so that it is distributed in different parts of the same room or adjoining rooms.

! It is mandatory that AT LEAST ONE OUTLET WITH NO CLOSING ELEMENT is connected FOR EACH FAN so as to ensure dissipation of the heat produced and ensure correct operation.

- the hot air ducting pipe MUST NOT come into contact with the smoke outlet or any other hot or moving parts, even if inside the appliance.

i Insulation, the ducting path and the position of the air vents affect the optimal heating of the environment. It is recommended that a specialised heating technician or engineer is consulted.

Knockout opening

Proceed as follows:

- remove the knockout (1) using a 6mm bit to drill through the prearranged holes (2); make sure that the product is not scratched or misshapen in the process

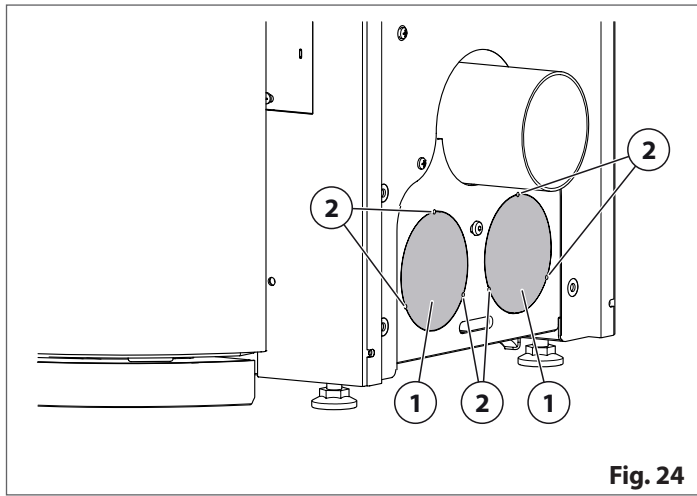

Fig. 24

6.3.3 Examples of ducting

Below are some examples of hot air ducting.

In order to create some of the solutions proposed, the installer needs not only the flexible duct of a suitable diameter but also vents for the air outlets and the Y elements, neither of which are provided but may be purchased separately.

i The maximum total length indicated in the section "CHARACTERISTICS":

- is to be reduced by 1 metre for each elbow connector and/or Y connector used
- is given by the sum of the individual lengths of pipes for each fan
- is subject to a check of the dimensions and the insulation classification of the environment to be heated and the ducting method.

i The flexible pipe can be curved and slightly deformed but it must not have any narrow sections or be blocked: this would compromise the hot air flow and appliance safety.

- A Smoke outlet
- B Hot air outlet in the front part or from the standard openings
- C Hot air outlet in other directions
- D Y element (for the flexible pipe)
- E Bend
- F Hose
- G Y element (for fan)

Hot air outlet only ducted from standard opening

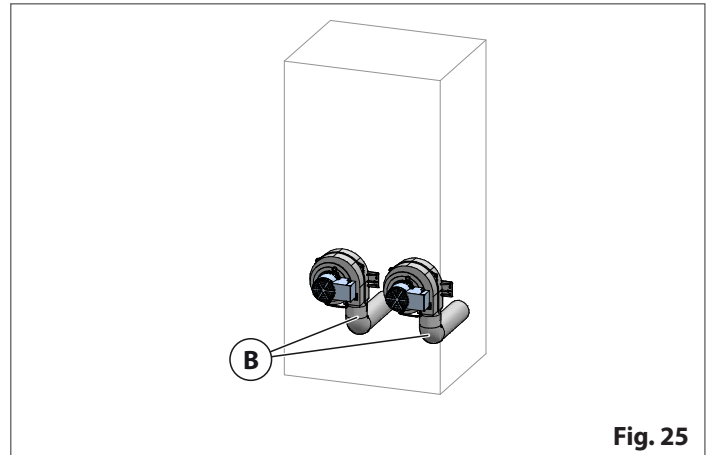

Fig. 25

Hot air outlet also ducted into a second room

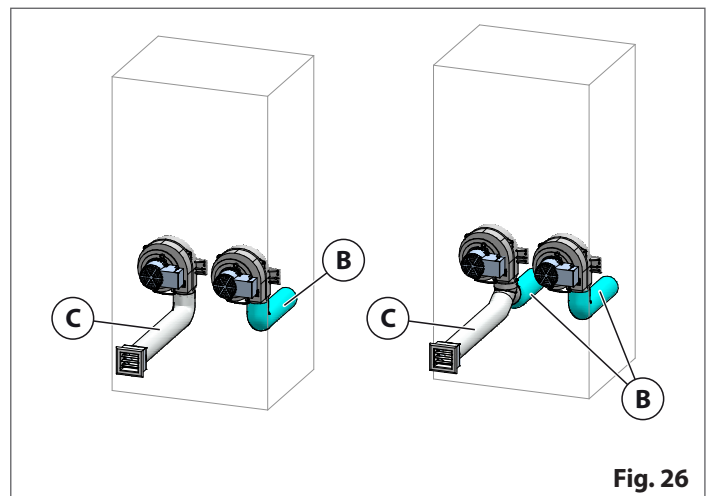

Fig. 26

Hot air outlet ducted into more than one room

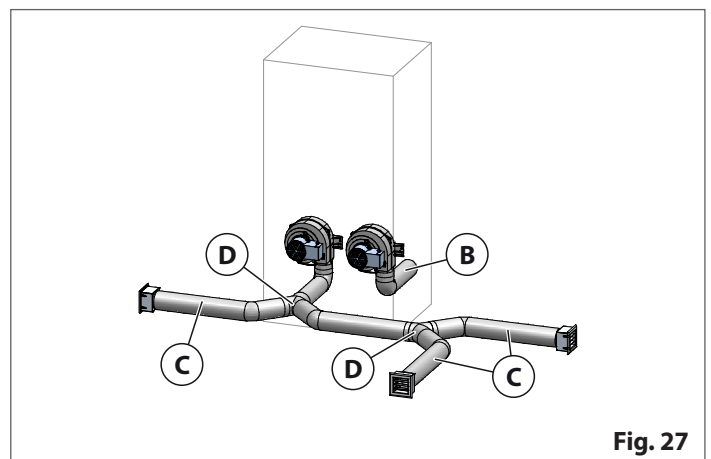

Fig. 27

First deviation connected directly to the fan outlet

For this appliance, in order to carry out diversions directly to the fan outlet, a section of flexible pipe (F) must be placed before connecting the Y element.

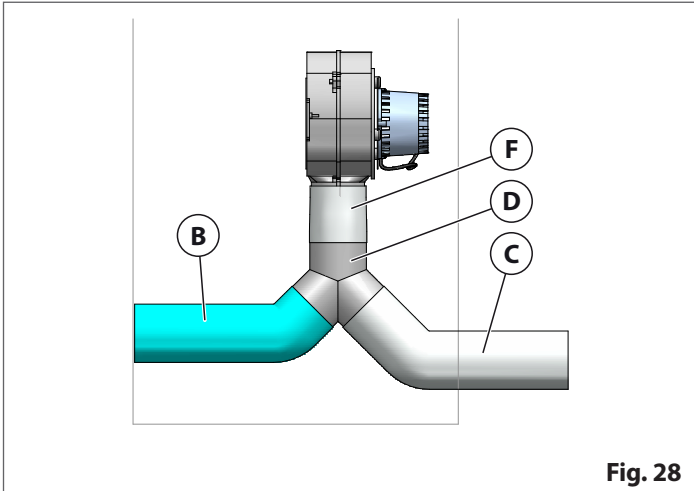

Fig. 28

6.3.4 Ducting indications

- For effective channelled heat distribution, you must:
- coat the pipe with a 2 cm thick insulating sheath (e.g. mineral fibre, ceramic fibre, rock fibre) in order to limit heat loss and to ensure an adequately high air temperature
 - ensure the insulating sheath has a specific weight equal to or greater than 50 kg/m³ with a minimum operational temperature limit of at least 250°C and thermal conductivity λ (100°C) ≤ 0.050 W/mK. The thermal insulation materials must have "AGI Q132" or "DIN 18895" labels.

! If the insulation material does not form part of flooring or walls, it must be fixed to the surface using fixing points spaced out at 30 cm intervals.

i The figures below show some examples of the positioning of the hot air vents on walls or on the floor.

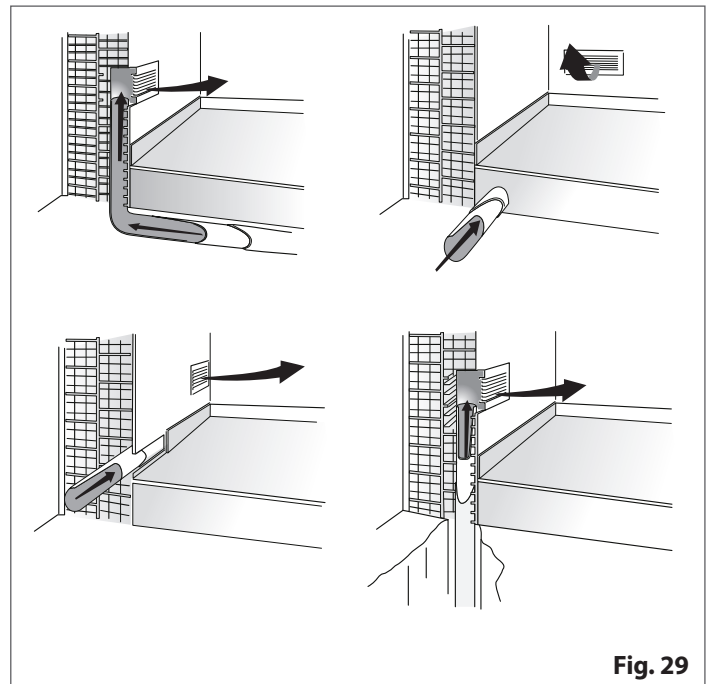

Fig. 29

6.3.5 Hot air outlet heating area

An area where the presence of flammable objects (furniture, carpets, curtains, etc.) or those affected by heat (wood, plastic, etc.) are forbidden is to be provided around the hot air outlet (1). The figure at the bottom shows the measurements relative to the safety area. This area is given considering 600 mm starting from the outside edge of the vent.

! Where there is flammable flooring, the hot air outlet vents must be placed at a distance of at least 200 mm from the floor.

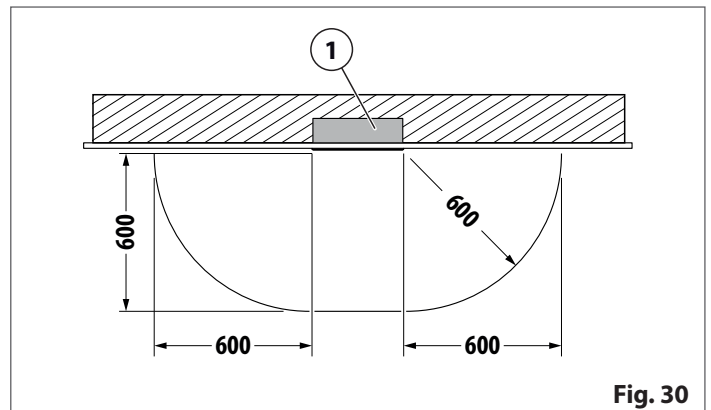



Fig. 30

6.4 COMBUSTION AIR CONNECTION

 Please refer to and carefully read the section "Fresh air intake".

 For the installation of any KITS and ACCESSORIES, please refer to the instructions provided with the kits or accessories.

Indications for the connecting pipe

It is recommended that a connection test is carried out before sealing and securing the various elements.

It is also recommended to:

- make the path as short and as straight as possible
- avoid unnecessary bends
- avoid any contact with hot parts, even unintentional contact (for example smoke outlet pipe)
- calculate beforehand the length of the connecting path then take a flexible pipe which is longer than necessary and can be cut to the correct length during the final phase
- secure the flexible pipe using a clamp and/or appropriate seal to make it airtight.

For the product to operate correctly, the ducting must have the following characteristics:

minimum diameter	6 cm	
maximum number of direction changes not greater than 90° (including first connection to appliance)	2	3
maximum ducting length	4 m	2 m

6.5 CONNECTION TO THE SMOKE OUTLET

 Please refer to and carefully read sections "FLUE PIPE" and "MINIMUM SAFETY DISTANCES".

The appliance is equipped as standard with the smoke outlet (1).

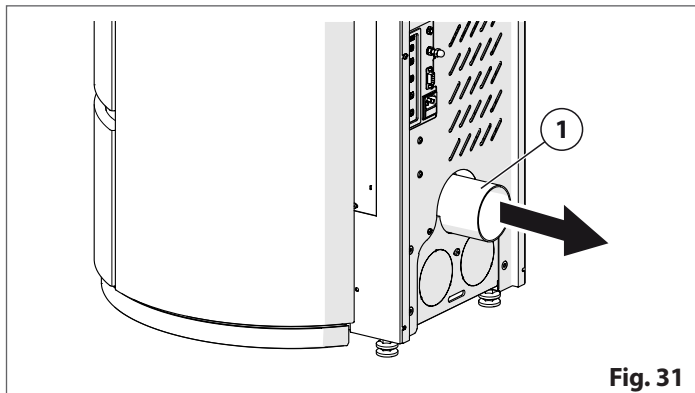

 For the installation of any KITS and ACCESSORIES, please refer to the instructions provided with the kits or accessories.

Additional requirements for the flue pipe

Gruppo Piazzetta S.p.A. supplies pipes and bends for the flue pipe, all of which are approved and specifically sized for the smoke outlet of its products.

Pipes approved by other manufacturers may also be applied as long as they have been appropriately adjusted, compatibility with the coupling has been checked and they comply with regulations.

In this case however, Gruppo Piazzetta S.p.A. can only ensure good operation for the products it manufactures or that it has tested and recognized and providing that installation and use comply with all specifications and regulations.

In the event pipes with a diameter greater than that of the appliance outlet are used, connect with an appropriate adapter (which is not supplied by Gruppo Piazzetta S.p.A.).

 It is recommended that elements with inspection apertures are used to facilitate periodic checks and cleaning of the flue pipe.

"T" connector

For good operation it is recommended that a "T" connector (1) is fitted as this allows the condensation to be collected, mixed with the soot which deposits on the inside of the pipe, and the first section to be periodically cleaned without having to disassemble the pipe.

This connector can be purchased from the dealer together with the pipes for the flue pipe..

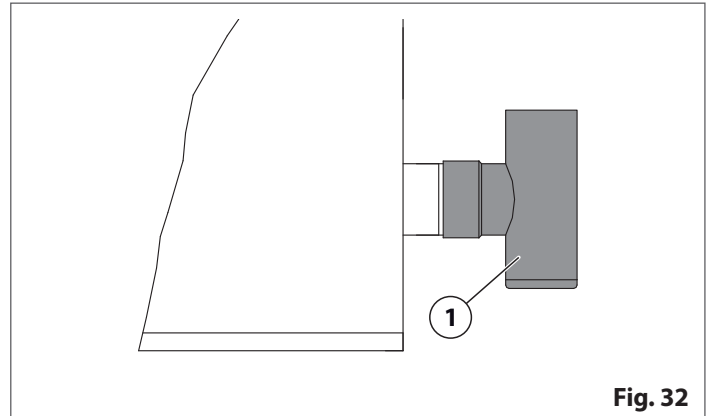

6.6 ELECTRICAL CONNECTIONS

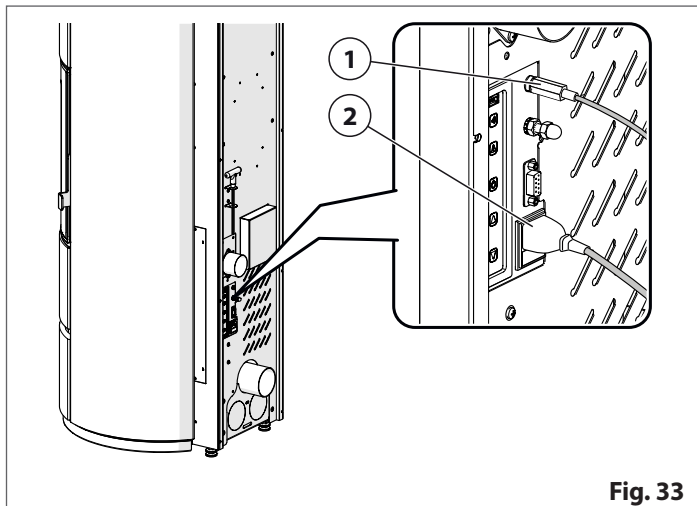

Fig. 33

- 1 Room probe connection
- 2 Power cable socket

i Only the power supply connection can be carried out by the user.

! All other electrical connections must be carried out by qualified personnel.
 ■ The electrical cables **MUST NOT** come into contact with hot or moving parts.

6.6.1 Power cable

The appliance comes supplied with a power cable which must be connected to a 230V~50Hz socket.

! The appliance must be connected to an effective earthing system.
 ■ Make sure that the power cable, in its final position, is not in contact with any hot parts and that the plug can be easily accessed after installation.

6.6.2 Room temperature probe

Connect the room temperature probe provided to the designated connector on the appliance. The bulb of the probe must be in a position which allows the most accurate reading of the room temperature to be taken.

i If the probe is not connected, an acoustic signal is given (refer to the manual "OPERATING INSTRUCTIONS" in the section "MESSAGES - ALARMS - ANOMALIES").

6.6.3 External environment thermostat

The appliance allows for connection to an external thermostat (not supplied as standard). This allows operation to be determined on the basis of the room temperature detected by the thermostat.

For installation:

- disconnect the appliance from the electrical power supply
- remove the right panel
- remove the fastening screws of the protective panel of the electronic board (3) and remove the board
- arrange a 2x0.5 mm cable² (2) and connect it to one side of the room thermostat (1)
- pass the other end of the cable below the base from the back of the stove and connect it to the 2 PIN terminal (5) supplied
- insert the terminal (5) into its own seat on the board (4)
- refit the protective board (3).

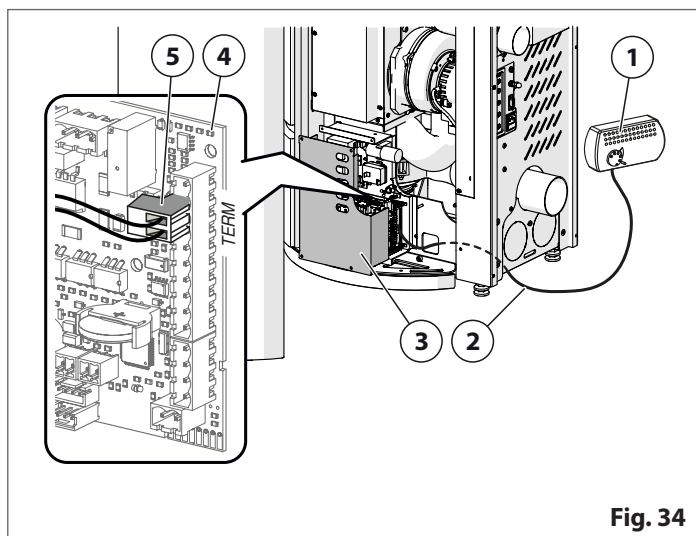

Fig. 34

- 1 External environment thermostat
- 2 2x0.5 mm² cable
- 3 Electronic board protection
- 4 Electronic board
- 5 2 PIN terminal

! Consent must arrive from a non-powered contact (normally open). Do not connect any live elements.

i Use a 2x0.5 mm² cable to make the connection !da duplicazione!.

i For information regarding operation, please refer to the manual "INFORMATION REGARDING OPERATION" in the section "EXTERNAL THERMOSTAT".

7 START-UP AND OPERATING TEST

A start-up and operational test must be carried out by a specialized qualified technician to check that the appliance and all other connected system elements operate correctly. It is therefore understood that depending on whether heating is via air or water, the hot air ducts present or the hydraulic circuit are to be checked along with other connected heat sources.

- i** Find out the cost of these operations from the specialised technician.
- Refer to the manual "*OPERATING INSTRUCTIONS*".

8 CLADDING AND TRIM

When installation has been completed, in addition to the indications given above, it may be necessary to fit accessories such as external cladding, parts and trims.

- i** If the external cladding and accessories are standard follow the instructions they are supplied with.

- i** Please follow indications provided in the section "*START-UP AND OPERATING TEST*":
- before completing the cladding assembly operations
 - after all cladding and construction interventions have been completed.

9 USE

- i** For information regarding operation, please refer to the manual "*OPERATING INSTRUCTIONS*".

9.1 HUMIDIFIER

The appliance is equipped with a system to humidify the environment.

- i** The humidifier is to be filled with water on average every two or three days and in any case, on the basis of appliance use.

- !** Do not fill the humidifier beyond the level marked "MAX". If any water were to leak out, it could damage the appliance.
- Refilling operations are to be carried out with the fire out and when the appliance has cooled down completely.
 - The humidifier is to be cleaned with the fire out, with the appliance off and disconnected from the electrical power source.

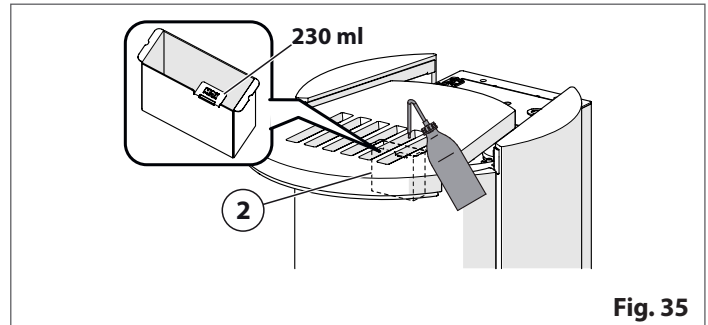

Remove the element (1) in order to remove the humidifier (2).

- !** Make sure that the product does not get scratched or damaged.

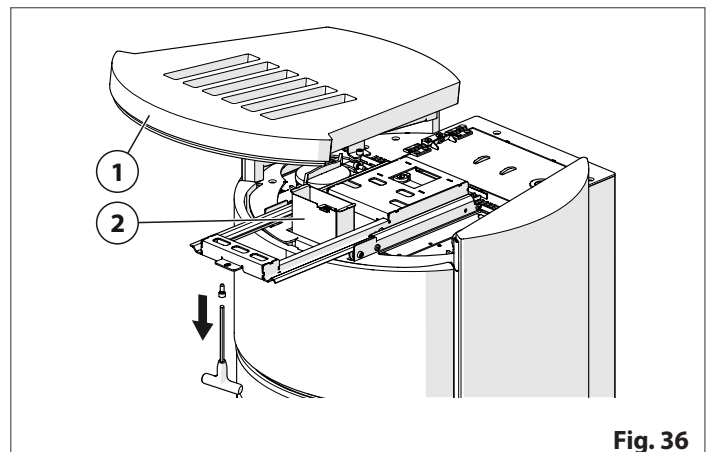

10 CLEANING AND MAINTENANCE

- !** For all installation and maintenance interventions which require access to inside the cladding, the smoke chamber or access to electrical and electronic parts, the user must contact a T.A.C. (Technical Assistance Centre) or qualified technician.
- All cleaning and maintenance work is to be carried out when the fire is out, the appliance is cold and with the power cable of the product itself and/or any other accessories disconnected.

 **At the end of maintenance operations:**

- restore and replace all worn or damaged parts with original spare parts
- restore all initial connections together with the normal operating conditions of the appliance and the system
- carry out a start-up and operating test to check that there are no faults.

Maintenance interventions are mandatory in order to ensure safety, for correct and efficient stove operation and to guarantee a long life of operation. If maintenance is not carried out with the recommended frequency, appliance performance could suffer and/or malfunctions could occur.

The manufacturer will not be responsible for appliance deterioration or malfunction if due to poor maintenance.

 **Cleaning must be carried out with suitable equipment and in full compliance with all health and safety regulations.**

- The materials and equipment used for cleaning must not alter appliance characteristics or operation in any way.
- The disposal of waste resulting from cleaning operations must be in full compliance with current laws and regulations on waste disposal.

10.1 SCHEDULED MAINTENANCE

 **Scheduled maintenance must be carried out at least ONCE A YEAR and in any case, before the commissioning of the appliance after a long period of inactivity.**

 **The time intervals are merely an indication: these intervals may need to be shorter depending on the frequency of use and the type of fuel used.**

 **At the end of maintenance operations:**

- all worn or damaged parts must be restored or replaced by original spare parts
- all initial connections together with the normal operating conditions of the appliance and the system must be restored
- a start-up and operating test must be carried out to check that there are no faults.

The following interventions are included in maintenance:

- checking the components for wear and ensuring they are integral and operate correctly
- checking there is no dirt, dust, deposits or obstructions
- checking that all components are positioned and secured correctly
- replacing damaged or worn components
- cleaning
- all interventions needed to ensure correct operation provided they are carried out in compliance with regulations.

Recommended interval

Interventions which may be carried out by the user	
Glass	1 day
Brazier and grate support	1 day
Ash drawer (if present)	2 days
Combustion chamber	7 days
The smoke outlet	1 month
Area behind the cladding panels (if there are no electrical components or moving electro-mechanical elements)	1 year
Remote control batteries (if present)	1 year
Operations which require the intervention of the T.A.C.	
Smoke chamber	1 year
Heat exchangers and smoke passages of the boiler body (if present)	1 year
Smoke outlet system	1 month
Fresh air intake and combustion air pipe	1 year
Ventilation system: vents, air ducting, grilles (if present)	1 year
Extractor fan	1 year
Room fans (if present)	1 year
Electrical parts and electronic components (if present)	1 year
Tightness and condition of the seals around the glass and all elements which are subject to wear	1 year
Area behind the cladding panels (if there are electrical components or moving electro-mechanical elements)	1 year

10.2 CLEANING THE CERAMIC CLADDING

Ceramic cladding must be cleaned with a soft dry cloth. If more strenuous interventions are required, use products which are suitable for cleaning ceramics as well as concentrated products for cleaning porcelain to remove oil, ink, coffee and wine stains etc.

 Do not soak the ceramic cladding or clean it with cold water when it is still hot as the thermal shock could cause it to crack.

10.3 CLEANING THE PAINTED METAL PARTS

When cleaning the painted metal parts, use a soft cloth moistened with water.

 Do not clean metal parts using alcohol, solvents, petrol-based products, acetones or other degreasing or abrasive substances. In the event of such substances being used, the manufacturer cannot be held responsible for any damage caused.

Discolouration of metal parts may be the result of misuse.

10.4 OPENING THE DOOR

Pull the handle towards you to open the door (1). It will now be possible to clean the inside of the glass or carry out appliance maintenance.

 The door must remain closed while the appliance is operating. The door may only be opened when the appliance is off and cold.

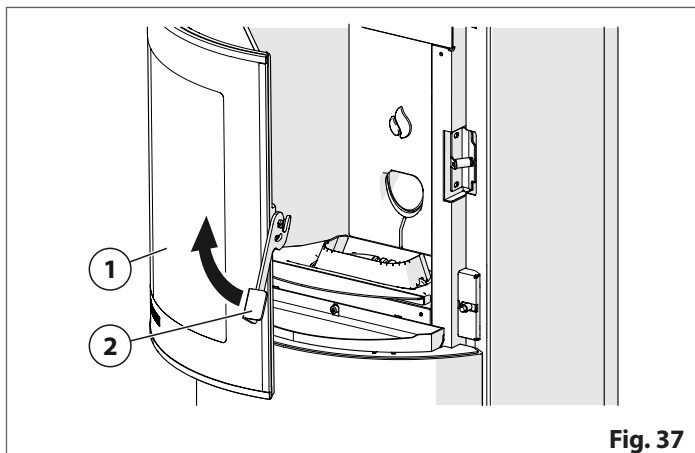



Fig. 37

10.5 CLEANING THE GLASS

During start-up it is possible that tar may accumulate on the glass which will disappear when optimal combustion is reached. If this does not happen, it is recommended that the glass is cleaned daily, before start-up, to prevent the formation of any deposits which would be difficult to remove.

 Recommended cleaning frequency: refer to the section "SCHEDULED MAINTENANCE".

 The glass should be cleaned when cold using ammonia-based non-corrosive degreasing agents (for example, do not use solvents).

- Do not use any material that could scratch or spoil the glass, as scratches may develop into cracks or breaks.

10.6 DISPOSAL OF ASH

Ash from natural (non-treated) wood burned in stoves or open fireplaces is composed mainly of calcium, silicon, potassium and magnesium. For this reason, it may be used as a fertilizer for plants, as long as 2.6 kg/10m² is not exceeded annually.

 The ashes should be placed in a metal container with a sealed cover. The sealed container should be placed on a non-combustible surface at a safe distance from combustible materials until the cinders have completely extinguished.

 Do not throw live cinders into waste containers.

10.7 CLEANING THE ASH TRAY

 Recommended cleaning frequency: refer to the section "SCHEDULED MAINTENANCE".

 For the disposal of ashes, please refer to the section "DISPOSAL OF ASHES".

10.8 CLEANING THE GRATE AND GRATE SUPPORT

The grate area must be cleaned.

 Recommended cleaning frequency: refer to the section "SCHEDULED MAINTENANCE".

- Before proceeding to start-up, any unburned pellets which are in the grate must be removed.

Proceed as follows:

- remove the grate deflector(1)
- release the grate (2) from its housing
- remove all ash and any deposits which may have formed, making sure that any clogged holes are cleared using an appropriate tool
- free the clogged holes on the top section (5) of the grate
- keep the "start-up hole" (3) at the rear of the grate clean
- check the grate support (4) and remove any ash present
- reposition the grate into its original position pushing it towards the start-up hole
- reposition the grate deflector.

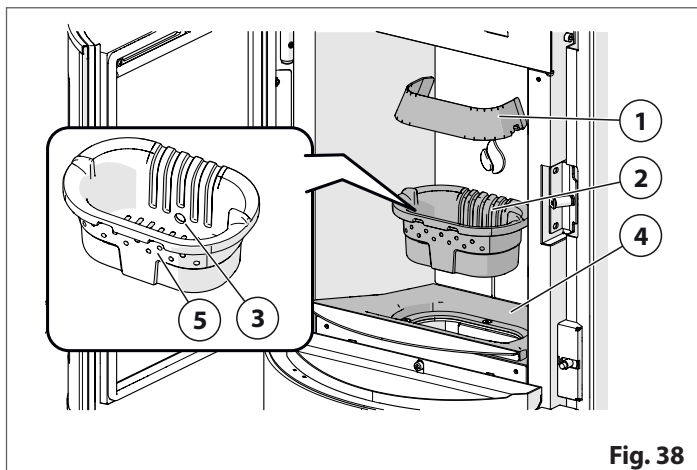

Fig. 38

! Before turning on the appliance, check that the grate is positioned correctly in its seat (and pushed towards the start-up hole).

- A vacuum cleaner which is suitable for use with ash is needed when carrying out this type of cleaning operation.

i To dispose of the ash, please refer to the section "DISPOSAL OF ASH".

10.9 CLEANING THE COMBUSTION CHAMBER

i Recommended cleaning frequency: refer to the section "SCHEDULED MAINTENANCE".

Proceed as follows:

- remove the grate deflector(1)
- release the grate (2) from its housing

- remove the Aluker back panel (3) lifting it slightly and removing it from the bottom

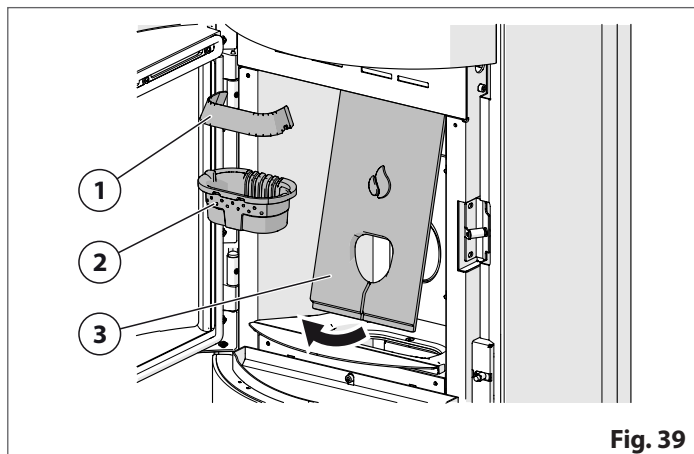

Fig. 39

- using a vacuum cleaner suitable for cleaning ash, remove all the residue which has deposited on the side walls and in the upper part of the firebox
- clean the parts which have been removed and then refit them in the reverse order in which they were removed
- close the firebox door

! A vacuum cleaner which is suitable for use with ash is needed when carrying out this type of cleaning operation.

i To dispose of the ash, please refer to the section "DISPOSAL OF ASH".

10.10 CLEANING THE SMOKE CHAMBER

i Recommended cleaning frequency: refer to the section "SCHEDULED MAINTENANCE".

- This operation facilitates an optimal heat exchange and better product performance.

Proceed as follows:

- remove the upper front panel following indications provided in the CLADDING instructions
- remove the upper smoke chamber cover (5) by using the hex wrench supplied and acting on the fastening screws (4)

- using a vacuum cleaner which is suitable for use with ash, remove all the residue deposited in the smoke chamber
- if necessary, remove the smoke deflector (6), clean it and reposition it in its seat

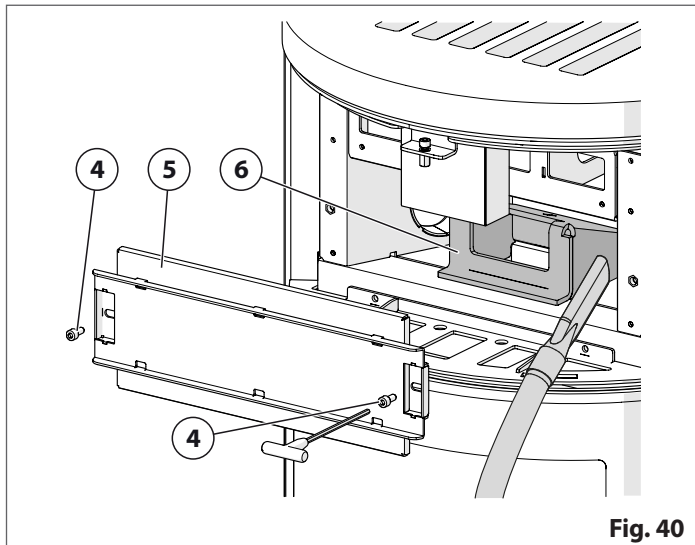

- check the state of the smoke chamber cover seal and have it replaced by the T.A.C. (Technical Assistance Centre) or qualified technician
- reposition the smoke chamber cover and the front panel refitting them in the reverse order from that used during removal
- remove the upper front panel following indications provided in the CLADDING instructions
- using the hex wrench supplied, remove the covers (1) of the flue pipes present in the top section of the stove
- using a ramrod of a suitable diameter, clean the entire length of the flue pipes. Make sure that no screws, nuts or bolts accidentally fall inside the pipes

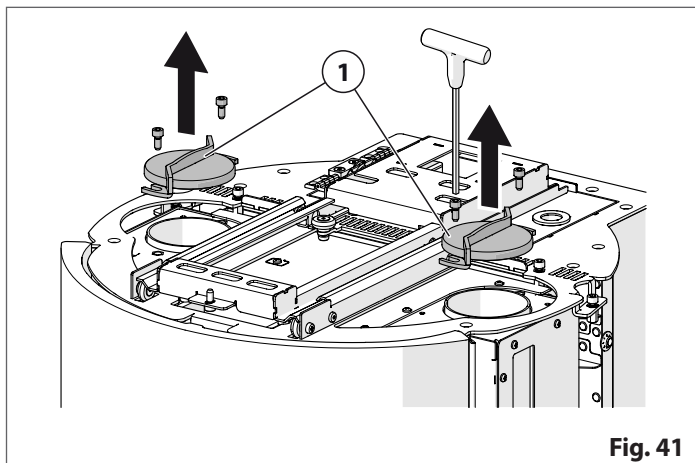

- remove the lower front panel following indications provided in the CLADDING instructions
- remove the lower smoke chamber cover (2) by using the hex wrench supplied and acting on the fastening screws

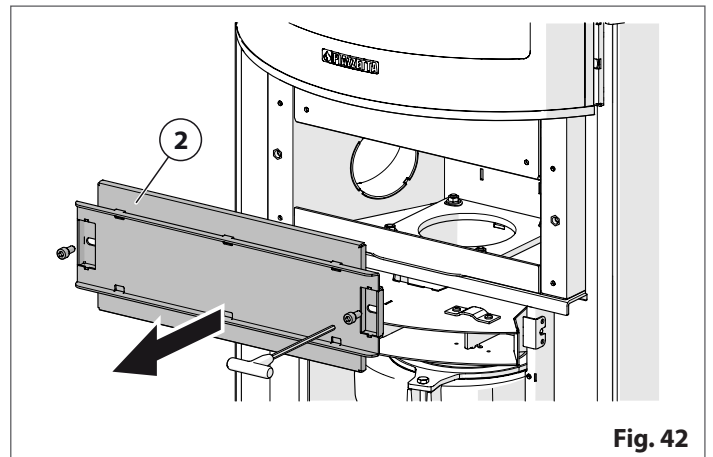

- clean the hole for the vacuum detection (3) inside the smoke chamber as indicated in the figure: for the appliance to operate correctly, the hole must always be free of dust and ash

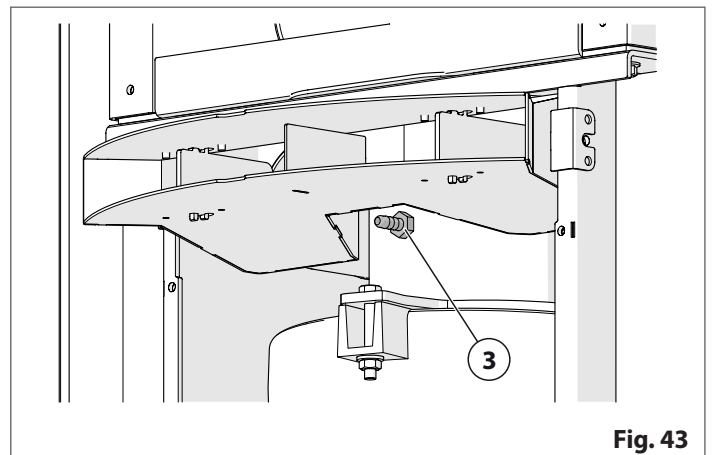

- check the state of the smoke chamber cover seal and replace if necessary
- reposition the smoke chamber cover and the front panel.

! A vacuum cleaner which is suitable for use with ash is needed when carrying out this type of cleaning operation.

i To dispose of the ash, please refer to the section "DISPOSAL OF ASH".

10.11 CLEANING THE EXTRACTOR FAN

Any dust or ash deposits on the smoke extractor fan blades may result in the fans becoming noisy when the appliance is in operation. It must be cleaned.

i Recommended cleaning frequency: refer to the section "SCHEDULED MAINTENANCE".

! The fan must be cleaned with the fire out, the appliance completely cold and with the power cable disconnected.

- The extractor fan is only to be cleaned by a T.A.C. (Technical Assistance Centre) or qualified technician.

10.12 CLEANING THE ROOM FAN

Any dust or ash deposits on the extractor fan blades may result in the fans becoming noisy when the appliance is in operation. It must be cleaned.

It is recommended that any deposits which may have formed in the hot air outlet grilles are also removed.

i Use a vacuum cleaner or compressed air cleaner for this.

- Recommended cleaning frequency: refer to the section "SCHEDULED MAINTENANCE".

! The fan must be cleaned with the fire out, the appliance completely cold and with the power cable disconnected.

- The extractor fan is only to be cleaned by a T.A.C. (Technical Assistance Centre) or qualified technician.

To access the room fan/s:

- remove the side panel/s following indications provided in the CLADDING instructions
- unscrew the screws and apply a slight pressure towards the front part of the stove to remove the cover (1) on the rear metal profile
- using the hex wrench provided, loosen the screw (2) securing the lower part of the fan flange
- remove the screws (3) securing the top part of the fan flange
- move the fan slightly and turn it towards the side of the stove
- proceed to clean the fan removing any dust residue
- it is recommended that a vacuum cleaner and a soft brush is used. Make sure the internal fan does not get damaged
- refit the fan, the cover and the side panel/s.

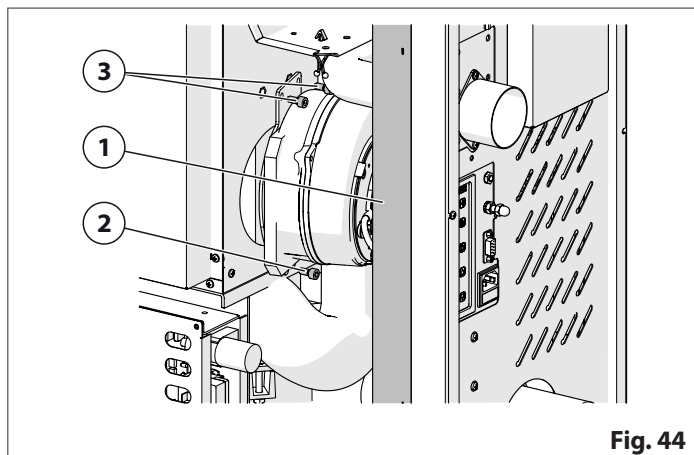

Fig. 44

10.13 CLEANING THE SMOKE OUTLET

The frequency with which the smoke outlet is to be cleaned depends on how much the appliance gathers dirt.

i Recommended cleaning frequency: refer to the section "SCHEDULED MAINTENANCE".

- Please refer to and carefully read the section "FLUE PIPE".

! If necessary, particularly on the first few occasions, we recommend calling a qualified technician.

Proceed as follows:

- Remove the plug from the T fitting (1) and clean the pipes

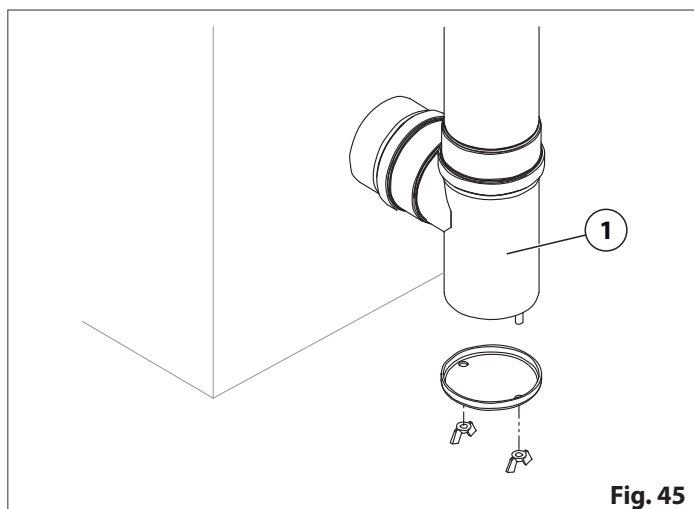

Fig. 45

10.14 REPLACING THE FUSES

FUSE ON THE IEC POWER SOCKET

Extract the fuse box drawer (1) in the power socket and replace the fuse with the spare to be found inside the small drawer or with another fuse of the same type.

Type of fuse: F4AL250V

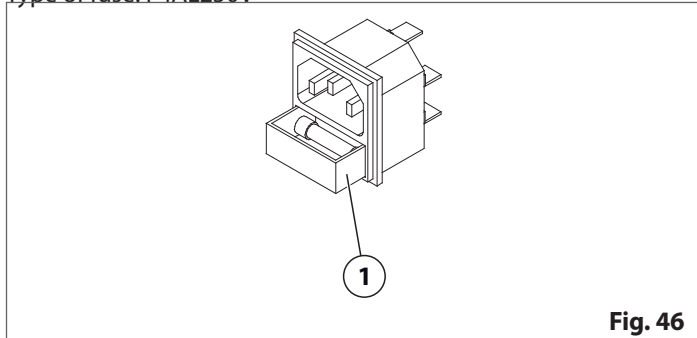

Fig. 46

ELECTRONIC BOARD FUSE

Unscrew the fuse box plug (1) located on the electronic board and replace the fuse with a similar one.

Type of fuse: F4AL250V

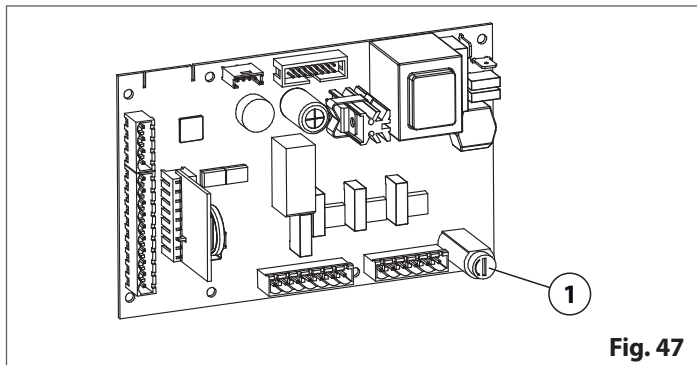

Fig. 47

To remove all pellets, proceed as follows:

- remove the pellets which are in the hopper, as far as the protection grille, when the fire is out and the appliance is completely cold
- switch on the appliance, allow it to operate until all the pellets have been depleted and the appliance switches off
- wait for the appliance to cool down completely.

i Excessive humidity and a long period of inactivity may cause the formation of rust on some of the unpainted parts inside the product.

- This is a natural situation and does not compromise the efficiency or life of the product and is not to be considered a defect.

i After a period of inactivity, the problem of expansion of the materials and emission of vapours could recur Refer to the section "NOTES REGARDING THE FIRST START-UP".

11 WHEN NOT IN USE

When shutting the appliance down at the end of the season or if a long period of inactivity is anticipated, proceed as follows:

- remove all pellets from the appliance
- carry out all the operations described in the section "CLEANING AND MAINTENANCE" so as to prevent deposits which would damage the product and would be difficult to remove when the appliance is next used
- ensure that checks, cleaning and maintenance operations not only on the appliance itself but also on the entire system (flue gas pipe, fresh air intake and suction pipes, hot air ducting, water-heating system etc) are carried out by specialised and qualified technicians
- if the product is equipped with a remote control, remove the batteries from the remote control unit to prevent any oxidation
- disconnect the product and /or any installed accessories from the electrical power source.

12 REFERENCE STANDARDS

Country of application: The European Union

EN 14785	Residential space heating appliances fired by wood pellets - Requirements and test methods
EN 60335-1	Household and similar electrical appliances. Safety - Part 1: General requirements
EN 60335-2-102	Household and similar electrical appliances. Safety - Part 2-102: Particular requirements for gas, oil and solid-fuel burning appliances having electrical connections
EN 1443	Chimneys - General requirements
EN 1457-1	Chimneys - Clay/ceramic flue liners - Part 1: Flue liners operation under dry conditions – Requirements and test methods
EN 1457-2	Chimneys - Clay/ceramic flue liners - Part 2: Flue liners operating under wet conditions - Requirements and test methods
EN 1806	Chimneys - Clay/ceramic flue blocks for single wall chimneys - Requirements and test methods
EN 1856-1	Chimneys - Requirements for metal chimneys - Part 1: System chimney products
EN 1856-2	Chimneys - Requirements for metal chimneys - Part 2: Metal flue liners and connecting flue pipes
EN 13384-1	Chimneys - Thermal and fluid dynamic calculation methods - Part 1: Chimneys serving one appliance
EN 15287-1	Chimneys - Design, installation and commissioning of chimneys - Part 1: Chimneys for non-roomsealed heating appliances
EN 13501-1	Fire classification of construction products and building elements - Part 1: Classification using data from reaction to fire tests
EN ISO 17225-1	Solid biofuels - Fuel specifications and classes - Part 1: General requirements
EN ISO 17225-2	Solid biofuels - Fuel specifications and classes - Part 2: Graded wood pellets

 **The installation of the product must be made in accordance with the manufacturer's instructions and in compliance with local regulations. Contact the fire service or competent authorities for clarifications on the restrictions and requirements in your area.**

European Standards

This product has been designed, tested and manufactured in compliance with European directives **R&TTE 2014/53/UE**.
On the basis of these directives, the product may be installed in the following countries

(BE) Belgium	(IT) Italy	(SE) Sweden
(DK) Denmark	(LU) Luxembourg	(UK) United Kingdom
(GR) Greece	(NL) Holland	(NO) Norway
(ES) Spain	(AT) Austria	(DE) Germany
(FR) France	(PT) Portugal	(CH) Switzerland
(IRE) Ireland	(FI) Finland	

Blank page with horizontal dashed lines for writing.



GRUPPO  **PIAZZETTA** S.p.A.

Via Montello, 22
31011 Casella d'Asolo (TV) - ITALY
Tel. +39.04235271 - Fax +39.042355178
www.piazzetta.it
e-mail: infopiazzetta@piazzetta.it