

# Pellet stoves **MARYON**

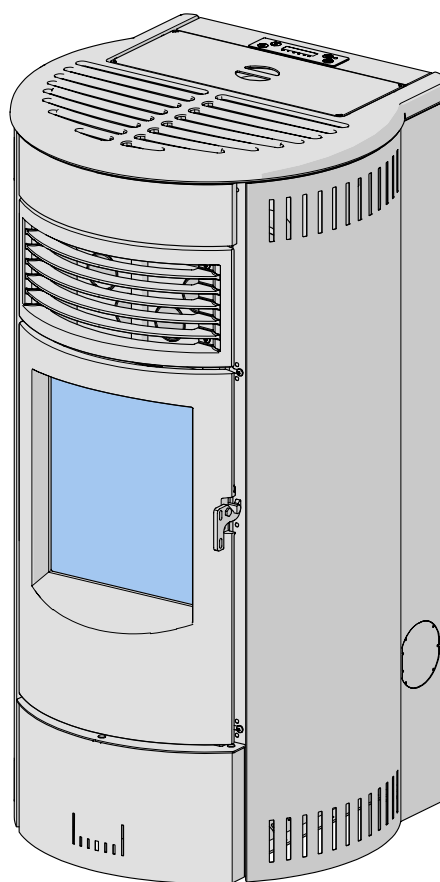

PRODUCT INFORMATION,  
INSTALLATION AND MAINTENANCE

 **SUPERIOR®**

**CE**

Dear Customer,

We thank you for having chosen one of our products, the fruit of extensive and continuous research for a superior product in terms of safety, reliability and performance.

In the documentation supplied, you will find all the information and advice you need to use your product as safely and efficiently as possible.



Please read the instructions and all information supplied with the product and any accessories, as well as any documentation referred to in this manual carefully, before proceeding with installation, use or any repairs.

- If any problems or doubts should arise, please contact your local dealer or the authorized T.A.C. (authorized technical assistance centre).



This manual contains INFORMATION REGARDING THE PRODUCT, INSTALLATION AND MAINTENANCE.

- For information regarding operation, please refer to the manual "*OPERATING INSTRUCTIONS*".

For the restrictions, limitations and exclusions please refer to the warranty included with the product. In line with its policy of constant product improvement and renewal, the manufacturer may make changes without notice.

**The images shown in this manual are for explanatory purposes and at times may not accurately depict the product.**

**Where provided for in the regulations applicable to your product, CERTIFICATES and DECLARATIONS are available IN ELECTRONIC FORMAT on our company website ([www.superiorstufe.it](http://www.superiorstufe.it)), under "Products", on the specific product characteristics page.**

**This document is the property of Superior and no part of it may be reproduced or disclosed to third parties, wholly or in part, without written permission. All rights reserved by Superior.**

## CONTENTS

<b>1</b>	<b>GENERAL INFORMATION</b>	<b>4</b>
<b>2</b>	<b>PRODUCT INFORMATION</b>	<b>6</b>
2.1	Product description	6
2.2	Part identification	7
2.3	Safety devices	8
2.4	Check devices	8
2.5	Product identification data	9
2.6	Characteristics	9
2.7	Accessories upon request	9
2.8	Technical data	10
2.9	Sizes	11
<b>3</b>	<b>FUEL</b>	<b>12</b>
3.1	Pellet specifications	12
3.2	Information regarding pellet loading	12
<b>4</b>	<b>GENERAL INFORMATION REGARDING THE SYSTEM</b>	<b>14</b>
4.1	Installation room	14
4.2	Fresh air intake	15
4.3	Chimney	15
4.4	Chimney terminal	16
4.5	Flue pipe	16
<b>5</b>	<b>PREPARATIONS FOR INSTALLATION</b>	<b>19</b>
5.1	Handling	19
5.2	Unpacking	19
5.3	Access to the internal parts of the product	19
<b>6</b>	<b>INSTALLATION</b>	<b>20</b>
6.1	Minimum safety distances	20
6.2	Combustion air connection	21
6.3	Connection to the smoke outlet	22
6.4	Electrical connections	22
<b>7</b>	<b>START-UP AND OPERATING TEST</b>	<b>24</b>
<b>8</b>	<b>CLADDING AND TRIM</b>	<b>24</b>
<b>9</b>	<b>USE</b>	<b>24</b>
9.1	Humidifier (accessories)	25
<b>10</b>	<b>CLEANING AND MAINTENANCE</b>	<b>25</b>
10.1	Scheduled maintenance	26
10.2	Cleaning the painted metal parts	26
10.3	Opening the door	27
10.4	Cleaning the glass	27
10.5	Disposal of ashes	27
10.6	Cleaning the ash tray	27
10.7	Cleaning the grate and grate support	28
10.8	Cleaning the smoke chamber	28
10.9	Cleaning the extractor fan	30
10.10	Cleaning the room fan	30
10.11	Cleaning the smoke outlet	30
10.12	Replacing the fuses	31
<b>11</b>	<b>WHEN NOT IN USE</b>	<b>31</b>
<b>12</b>	<b>DISPOSAL OF PRODUCT AT END OF PRODUCT LIFE</b>	<b>32</b>
12.1	Electrical and electronic waste	32
<b>13</b>	<b>REFERENCE STANDARDS</b>	<b>33</b>
<b>14</b>	<b>APPENDIX</b>	<b>34</b>
	<i>Identification data plate: key</i>	34

## 1 GENERAL INFORMATION

**Definition:** The term **system** indicates the unit consisting of the appliance and all the necessary installations which affect its operation, including air intakes, the entire system for the evacuation of the flue gases (connecting flue pipe, flue, chimney terminal) the area, other sources of heat, installations for the propagation of heat (hot air ducting or plumbing system).

**Definition:** The term **standards** or **regulations** indicates all applicable European or national legislation, local regulations, particular or conventional requirements arising from joint ownership building regulations, and easement or laws or administrative acts, in force in the country where the appliance is to be installed.

**Definition:** The term **airtight appliance** refers to a specifically designed appliance which takes in the air needed to operate correctly from outside the installation room. The term **airtight installation** refers to the installation of these types of appliances in such a way that all the air needed for combustion is taken in from the outside.

- This instruction booklet has been prepared by the manufacturer and is an integral part of the product. In the event of sale or relocation of the product make sure this booklet accompanies it, since the information contained in it is addressed to the purchaser and to anyone involved in the installation, use and maintenance of the product.
- Please read the instructions and all information supplied with the product and any accessories, as well as any documentation referred to in this manual carefully, before proceeding with installation, use or any repairs. If any problems or doubts should arise, please contact your local dealer or the authorized T.A.C. (authorized technical assistance centre).
- Superior cannot be held liable for situations of risk, defects, damage, product malfunctioning or for damage to objects, people or animals resulting from tampering of the appliance and installation, use and maintenance which does not respect the indications provided by regulations and the manufacturer.
- Any changes to the original parameters which determine product operation may only be carried out by authorised persons from the company and with the values set by the manufacturer. Non-authorized interventions on the product will be considered tampering.

 All local regulations, including those referring to national and European Standards need to be complied with when installing the appliance and when operating the appliance.

- Product installation, use and maintenance must be carried out in compliance with the applicable instructions provided by the manufacturer and in compliance with all relevant regulations. Failure to respect the indications provided and any incorrect interventions may create dangerous situations, cause damage to people, property or animals, or lead to health problems or operating faults.

 Product installation and maintenance must be carried out exclusively by qualified personnel with sufficient knowledge of the product itself.

- Only use original spare parts as recommended by the manufacturer.

 In the event of a malfunction or fault, before carrying out any intervention and before discontinuing product use, please refer to the manual provided by the manufacturer in the sections "FAULTS" or "MESSAGES - SAFETY WARNINGS - ANOMALIES".

 In the event of fire in the flue, stop using the appliance, do not open the door of the appliance, observe all safety recommendations and contact the appropriate authorities.

- For appliances which are powered electrically, do not disconnect the power supply if unburned smoke/gas forms inside the firebox. Move away and adopt all necessary safety precautions.

 Smoke coming from a blocked flue is dangerous. Keep the flue and connecting flue pipe clean. Follow the manufacturer's cleaning instructions.

- Keep the exchangers and smoke passages on the boiler clean. Follow the manufacturer's cleaning instructions.
- Only use the recommended fuel.
- Please read and comply with the instructions for installation, use and maintenance.

 Product use may cause some surfaces to become extremely hot (the glass, the external surfaces, the handles, the smoke outlet passage). Any contact between clothing or body parts and these surfaces, including where accidental, may cause burns or fires.

- Before performing work on parts of the appliance that may be hot (e.g. top surface panel, grilles, covers, door, settings devices and control devices), take the necessary precautions and use suitable protective devices (glove, fire door opening tool or other specific devices).
- Since the glass becomes hot, make sure that no person other than those experienced in operating the appliance remain in the area from where the heat emanates.

 Everyone (both children and adults) should be informed of the risk of coming into contact with hot surfaces.

- Babies, young children, animals or anyone else may experience burns as a result of accidental contact. If there are any at-risk subjects in the home, a protective barrier should be installed. To limit access to the appliance, install a safety gate to keep babies, young children and other at-risk subjects out of the room and away from the hot surfaces.

 This appliance can be used by children aged 8 and above and persons with reduced physical, sensory or mental capabilities or lack of experience and knowledge if they are supervised or have been instructed concerning use of the appliance in a safe way and understand the hazards involved.

- Children shall not play with the appliance. Cleaning and user maintenance shall not be made by children.

 During the operation and/or cooling phase, slight creaking noises may be heard. This is not considered a defect, but is a consequence of the thermal expansion of the materials used.

 It is forbidden any unauthorized modification of the appliance.

 Do not stand or place objects which are not heat-resistant within the prescribed minimum safety distance.

- This also applies when the appliance is off. The appliance may be turned on by somebody else or, where the appliance is pre-configured, may be automatically switched on (programmed or via remote control), at any time.
- Do not place food, drinks or other containers with liquids on parts of the appliance or the surround, except for compartments specifically designated by the manufacturer for cooking or warming up food.

 Do not install the product near walls or objects in heat-sensitive or combustible material (wood or similar). It is important to observe and respect the distances and safety indications prescribed by regulations and indicated in the manual provided by the manufacturer in the section "*INSTALLATION*".

- **IT IS FORBIDDEN TO USE THE APPLIANCE WITHOUT SUITABLE CLADDING.**

 Never use gasoline, gasoline-type lantern fuel, kerosene, charcoal lighter fluid, ethyl alcohol or similar liquids to start or "reignite" a fire in this heater. Keep all such liquids well away from the heater while it is in use.

- Only power the appliance with fuel which has the characteristics as indicated in the section "*FUEL*" in the manual provided by the manufacturer.

-  Do not use the appliance as an incinerator or in any way other than that for which it was designed.
- Do not use the appliance if the glass or seals on the door are damaged.
  - Do not open the door during operation. When using wood fired appliances, only open the door for the time strictly necessary to reload the fuel and in the manner indicated in the section "*OPENING THE DOOR*" in the manual provided by the manufacturer.

Before carrying out any assembly, installation or ignition procedures, the enabled installer must check that the system has been manufactured in compliance with the applicable instructions provided by the manufacturer and in compliance with all relevant regulations. In particular, check:

- suitability of the room where the appliance is to be installed as well as any restrictions
- the existence of any other appliances
- fresh air intake
- ventilation within the area where the appliance is to be installed
- sufficient clean air flow for combustion: air cannot be taken from potentially polluted areas
- smoke evacuation system comprising a connecting flue pipe, flue and chimney.

Installation may also include a series of operations to be carried out correctly by enabled personnel and for which system compatibility must be guaranteed:

- connection to the air intake
- connection to the smoke evacuation system
- ventilation
- assembly and installation
- any necessary electrical or plumbing connections
- insulation
- start-up and operating tests, and where necessary calibration and adjustment
- cladding and trims
- presentation of additional documentation as prescribed by the regulations
- end user training by the installer on how to use and maintain the appliance
- checking and maintenance.

Other requirements for compliance may be necessary in relation to specifications required by the appropriate Authorities.

## 2 PRODUCT INFORMATION

### 2.1 PRODUCT DESCRIPTION

This appliance is:

- a heat generator designed to be run with pellets
- designed to be used at altitudes not exceeding 2000 m
- to be used solely for the purpose for which it was designed; all other uses are to be considered improper and therefore dangerous
- equipped with a flue evacuation fan which maintains the combustion chamber in negative pressure.

The use of a fuel which can be easily transported and stored such as pellets, facilitates the ease of use of this appliance.

The control unit allows the user to manage a range of functions and programmes, while the basic controls can also be managed using the control panel on the appliance itself.

The pellets are loaded into the hopper manually and the ignition is electronic.

An electronic control unit controls the pellet dosing into the grate as well as the flue gas expulsion.

The unit controls the appliance to make sure it operates correctly. Thanks to a series of safety devices, it signals any faults and, if necessary, initiates the appropriate procedures.

The main appliance functions can be managed using the Wi-Fi/Bluetooth equipment for remote control installed on the appliance and the MYSUPERIOR app installed on a mobile device.

#### Airtight appliance

The airtight appliance is constructed to intake combustion air directly from outside without consuming the oxygen of the place of installation.

If this connection is made, it is not necessary to make free ventilation vents in the installation room, preventing in this way the flow of cold air which would make the room less comfortable and compromise the overall efficiency of the system.

This characteristic makes these appliances suitable for installation within homes with low energy consumption or passive houses equipped possibly with mechanically controlled ventilation systems that allow the exchange of fresh air to be continuous and controlled.

2.2 PART IDENTIFICATION

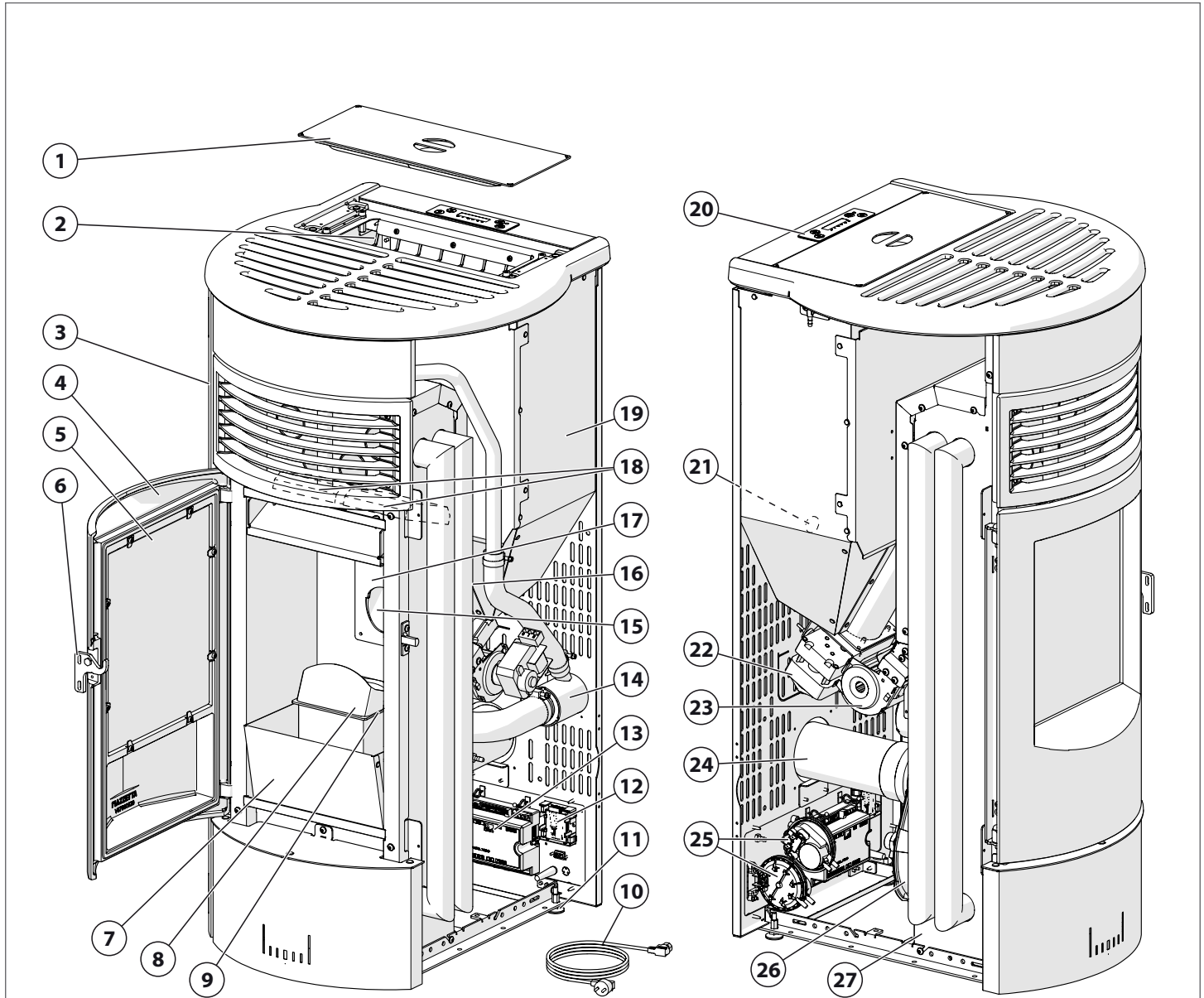

- |   |                               |
|---|-------------------------------|
| 1 Pellet hopper cover                           | 18 Smoke deflector            |
| 2 Pellet hopper grille                          | 19 Pellet hopper              |
| 3 Cladding                                      | 20 Appliance control panel    |
| 4 Door  | 21 Pellet indicator           |
| 5 Ceramic glass                                 | 22 Auger motor                |
| 6 Door handle                                   | 23 Environment fan/s          |
| 7 Ash drawer                                    | 24 Smoke outlet               |
| 8 Grate deflector                               | 25 Pressure switch            |
| 9 Grate   | 26 Smoke intake/Extractor fan |
| 10 Electrical power cable                       | 27 Metal structure            |
| 11 Adjustable feet                              |                               |
| 12 Wi-Fi/Bluetooth equipment for remote control |                               |
| 13 Electronic control unit                      |                               |
| 14 Combustion air duct                          |                               |
| 15 Pellet delivery hole                         |                               |
| 16 Thermal cut-out                              |                               |
| 17 Combustion chamber                           |                               |

Fig. 1

## 2.3 SAFETY DEVICES

The appliance is equipped with the following safety and check devices which stop the stove from operating if any faults occur. If any safety warnings or alarms are activated, please consult the "OPERATING INSTRUCTIONS".

### Pressure switch:

controls the vacuum inside the appliance. The pressure switch is activated if the correct operating conditions are altered (inappropriate use or installation, obstacles or blockages in the flue, lack of maintenance, adverse weather conditions such as persistent wind etc.). The pressure switch activates and isolates the supply voltage to the auger, thus stopping pellet feed to the grate and then initiates the appliance shut down process.

### Fuel hopper thermal cut-out:

this is a thermal device with automatic rearming that serves to safeguard the pellet hopper against excessive temperatures. If the temperature of the hopper exceeds the safety threshold, the device isolates the supply voltage to the auger, pellet feed to the grate is stopped and the appliance shut-down procedure begins.

### Smoke temperature probe:

this is connected to the electronic control unit and constantly monitors the operating temperature. If during this phase the smoke temperature:

- a) *exceeds the safety threshold, the electronic control unit isolates the supply voltage to the auger, thus stopping pellet feed to the grate and starting the appliance shut down process*
- b) *falls below the minimum operating temperature, the appliance stops and an acoustic alarm signal is activated.*

Furthermore, if during the start-up phase a system malfunction is detected, an acoustic alarm signal is activated.

### Auger safety:

the operation of the auger is constantly monitored by the electronic control unit. In the event of a malfunction, an acoustic safety signal is activated. The electronic control unit isolates the supply voltage to the auger, thus stopping pellet feed to the grate and starting the appliance shut down process.

### Extractor fan safety:

the rotation of the extractor fan is constantly monitored by the electronic control unit. In the event of a fan malfunction, an acoustic alarm signal is activated. The electronic control unit isolates the supply voltage to the auger, thus stopping pellet feed to the grate and starting the appliance shut down process.

### Electrical safety:

the appliance is protected by fuses in the event of a power surge.

### Electronic control unit:

the electronic control unit signals and controls a series of events including power and ignition failure.



The safety devices are there to eliminate the risk of damage or injury to persons, animals or objects. IT IS FORBIDDEN to tamper with the safety devices or allow any intervention to be carried out by non-qualified personnel.

## 2.4 CHECK DEVICES

The appliance is equipped with some check devices which are to be used exclusively by personnel authorised to carry out fine tuning operations during installation and maintenance procedures.

**Pressure plug (A):** for measuring the pressure drop inside the appliance.

**DB9 serial port (B):** to carry out checks on the correct operation of the product and any necessary maintenance operations. A remote appliance-management system (GPRS or Wi-Fi) can be connected to the DB9 serial port.

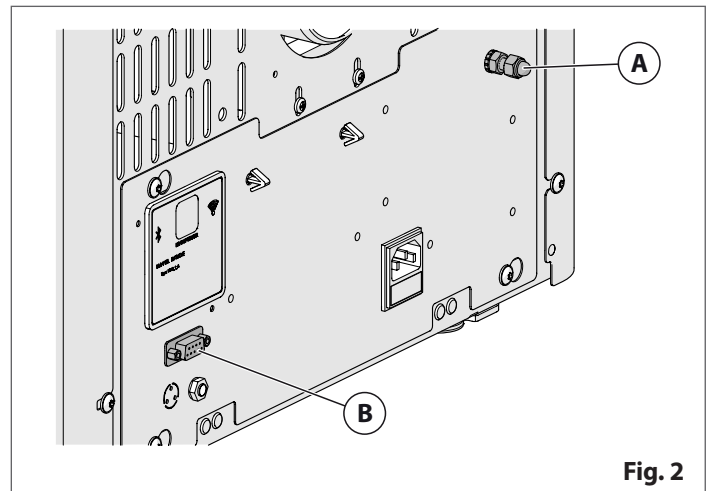

Fig. 2



## 2.5 PRODUCT IDENTIFICATION DATA

Each product is identified in the following way:

- **IDENTIFICATION DATA PLATE** (1) with the model (A) and appliance performance specifications
- **SERIAL NUMBER PLATE** (2) with the serial number of the appliance (B)
- **LABEL WITH IMPORTANT ADDITIONAL INFORMATION** (3) with important information.

The identification plates are positioned as shown below.

**i** When asking for technical support and/or spare parts, always provide these data to the dealer or T.A.C. (authorised technical assistance centre).

**i** If more than one model depending on the cladding is shown on the identification data plate, the installer must mark the box according to the installation.

**1**

**A**

Model

- 00
- 0000
- 000
- 0000 00
- 

**2**

**B** MATR. ...

**3**

**Fig. 3**

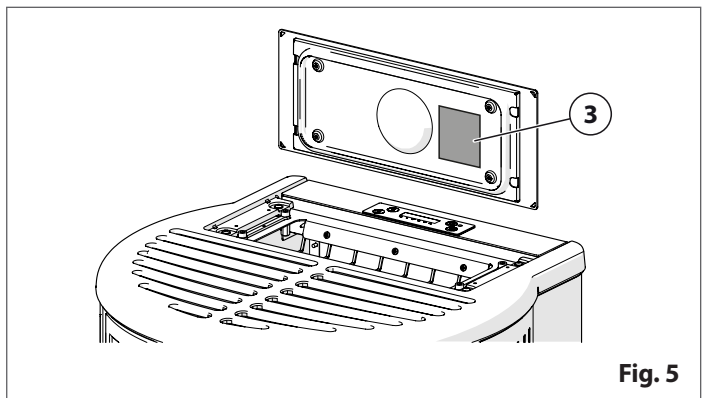
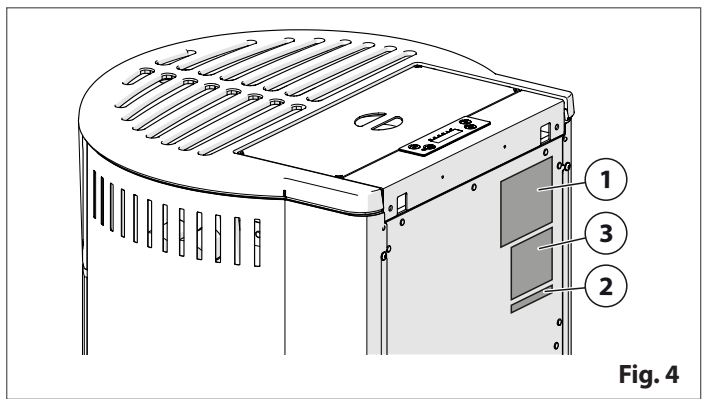

## 2.6 CHARACTERISTICS

**Structure:**

- in steel

**Cladding:**

- in painted steel

**Firebox:**

- in steel

**Smoke deflector:**

- in Skamolex

**Grate:**

- in cast iron

**Ash collection:**

- extractable ash drawer

**Door:**

- in cast iron
- ceramic glass resistant to 750°C (1382 °F)

**Door handle:**

- in painted steel

**Power adjustment:**

- 5 positions

**Heating:**

- through forced ventilation
- 1 fan

**Function control:**

- Wi-Fi/Bluetooth equipment for remote control
- appliance control panel

**Provided as standard:**

- Schuko cable IEC (length 2 m)
- room temperature probe
- grate deflector
- firedoor opening tool
- ramrod

## 2.7 ACCESSORIES UPON REQUEST

To consult the full list of accessories supplied upon request and to check the compatibility of internal components, cladding and accessories, consult your dealer.

- Remote control kit
- Floor protection
- Accessories for flue connection (pipes,bends, flanges etc...)
- Smoke outlet kit
- Accessories for combustion air ducting
- Humidifier (in stainless steel)
- Accessories for cleaning and maintenance

## 2.8 TECHNICAL DATA

Description	Model	MARYON	
	Type	SP450-02	
	Unit of measurement	at nominal heat output	at part load heat output
Fuel		natural pure wood pellets	
Heat Output	kW	8,5	3,3
Hourly fuel consumption	kg/h	1,93	0,76
Efficiency	%	91,2	89,3
Flue gas temperature	°C	172,1	108,8

### CONTENT OF SMOKE EMISSIONS

CO at 13% of O2	% (mg/Nm <sup>3</sup> )	0,003 (34)	0,056 (706)
CO at 0% of O2	mg/MJ	23	477
Particulate at 13% O2 (at 0% O2)	mg/Nm <sup>3</sup> (mg/MJ)	14 (9)	17 (11)
OGC at 13% O2 (at 0% O2)	mg/Nm <sup>3</sup> (mg/MJ)	1 (1)	7 (5)
NOx at 13% O2 (at 0% O2)	mg/Nm <sup>3</sup> (mg/MJ)	120 (81)	100 (67)

### ELECTRICAL DATA

Maximum electrical power input (during ignition)	W	330	
Electric power in operation	W	56	35
Electric power in standby mode	W	2,3	
Rated voltage (rated frequency)	V (Hz)	230 (50)	

### DIMENSIONAL DATA

Approximate hopper capacity	kg (l)	22 (33,5)	
Diameter of the flue gas outlet	mm	80	
Weight of appliance with cladding	kg	98	

### FRESH AIR DATA

Fresh air intake (minimum useful section)	cm <sup>2</sup>	80	
---	-----------------	----	--

### CERTIFICATION DATA

Test report	N°	K 3162 2021 T1	
Notified body	N°	2456	
Declaration of performance	N°	H07900413	
Energy efficiency class - Regulation (EU) 2015/1186		A+	

### TECHNICAL DATA FOR FLUE CALCULATIONS

Smoke flow	g/s	5,1	4,3
Flue gas outlet temperature	°C	207	131
Minimum draught	Pa	5	3

SAFETY DISTANCES (refer to the section "MINIMUM SAFETY DISTANCES")			combustible materials	non-combustible materials
A	Product air distance from rear wall	mm	50	50
B	Product air distance from side walls	mm	300	150
C	Area free from combustible or heat-sensitive materials	mm	1000	
D	Distance of front floor protection overhang	mm	300	-
E	Distance between inside edge of firebox opening and the edge of the floor protection	mm	300	-
H	Distance clear from top edge of product	mm	750	
L	Air distance from the floor	mm	0	0

Laboratory data, in accordance with the product technical regulations.

The above data vary in relation to the size and type of fuel used (refer to the section "FUEL"), chimney vacuum and system characteristics. Data regarding the electric absorption vary depending on the network voltage and any KITS or ACCESSORIES which have been installed. Refer to the instructions attached to the Kits or accessories.

2.9 SIZES

(values in cm)

MARYON

Fig. 6

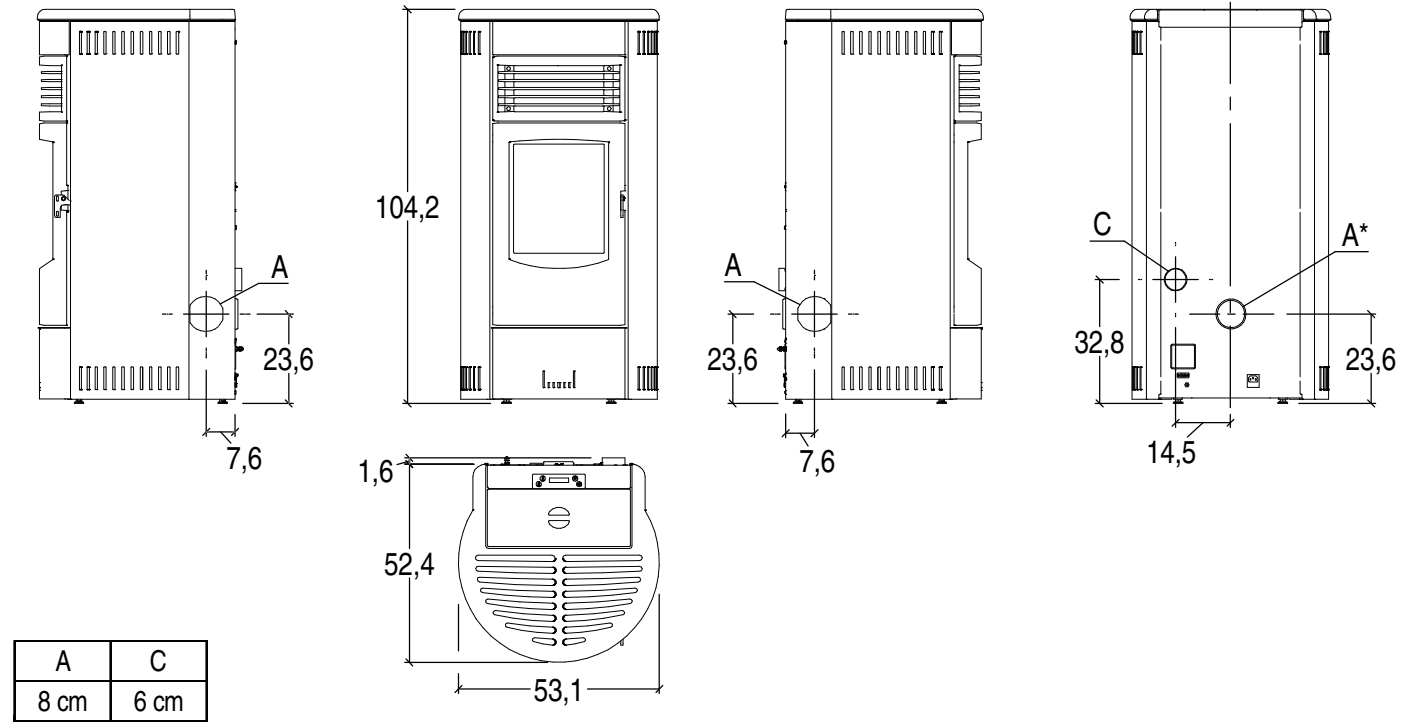

- A** Smoke outlet
- C** Combustion air duct
- \*** standard position

### 3 FUEL

#### 3.1 PELLET SPECIFICATIONS

 Under no circumstances use fuel other than pellets.

 DO NOT use pellets with dimensions other than those recommended by the manufacturer.

There are various types of pellet on the market with qualities and characteristics that vary depending on the processes they have undergone and the type of wood used in their production. Since the characteristics and quality of the pellet considerably affect product performance, efficiency and proper operation, we recommend that you use "premium grade" pellets: **certified and in compliance with the requirements of class A1 (EN 17225-2)**.

In order to guarantee efficient product operation, Superior has tested and programmed its own products with pellets with the characteristics as shown in the table.

Original raw material	Natural pure wood pellet
Length	10 ÷ 30 mm
Diameter	6 mm
Apparent density	≥ 600 kg/m <sup>3</sup>
Net calorific value	≥ 4,9 kWh/kg
Moisture	≤ 6 %
Ash residue	≤ 0,7 %

**Note:** the above data refer to fir wood pellets

Using good quality pellets but with dimensions and heat-producing properties different from those above may require the appliance operating parameters to be changed.

 This "customisation" of appliance operating settings must only be carried out by a T.A.C. (technical assistance centre) or by specially qualified personnel authorised by Superior.

- Using pellets that are out of date or not in conformity with the manufacturer's recommendations not only damages the stove and jeopardises its performance, but can render the guarantee null and void and relieves the manufacturer of all liability.

 DO NOT use pellets containing sawdust, bark, maize, resins or chemical substances, additives or adhesives.

- DO NOT use damp pellets.

The technical characteristics can be determined only using the relevant tools, but a visual check at the time of purchase can serve to identify:

- good quality: shiny, smooth, regular length, minimal dust
- poor quality: horizontal and diagonal splits, irregular length, abundant dust

**Choosing other unsuitable pellets may:**

- obstruct the grate and flue gas pipe
- increase fuel consumption yet reduce performance
- mean that proper stove operation cannot be guaranteed
- cause dirt to build up on the glass
- leave particles which have failed to burn and heavy cinders.

**The presence of moisture in the pellets increases their volume and causes them to split which in turn causes:**

- malfunction of the fuel-loading system
- inefficient combustion.

**Pellets must be stowed in a dry, sheltered place that complies with the relevant safety clearances from the appliance and from heat sources which could cause combustion.**

#### 3.2 INFORMATION REGARDING PELLET LOADING

In order to load pellets into the hopper, we recommend removing the bag flap opening and emptying it into the hopper. This way, the loading operation is easier and you avoid spilling the pellets over the appliance.

 Do not allow the build-up of residue at the bottom of the hopper.

- Do not empty any residue from the pellet bag into the hopper.
- During loading operations, make sure that no pellets fall out of the hopper as they could come into contact with hot surfaces and ignite.
- Do not leave leftover pellets on top of the stove: they could catch fire.
- Do not fill the pellet hopper in excess of normal capacity and do not compress the fuel.

 Some appliances are equipped with a protection grille inside the hopper. Removing this grille is forbidden.

- Only keep the cover of the pellet hopper open for as long as it takes to complete the refill operation. To ensure optimal operation, some models activate an error signal in the event the hopper cover is left open for a time exceeding the set time.

 Do not rest the pellet hopper cover on the appliance stove surface when the stove is still hot.

### 3.2.1 Pellet indicator

When the red reload indicator can be seen inside the hopper, it is possible that the auger is not perfectly loaded which would cause irregular pellet unloading in the grate and start-up failure.

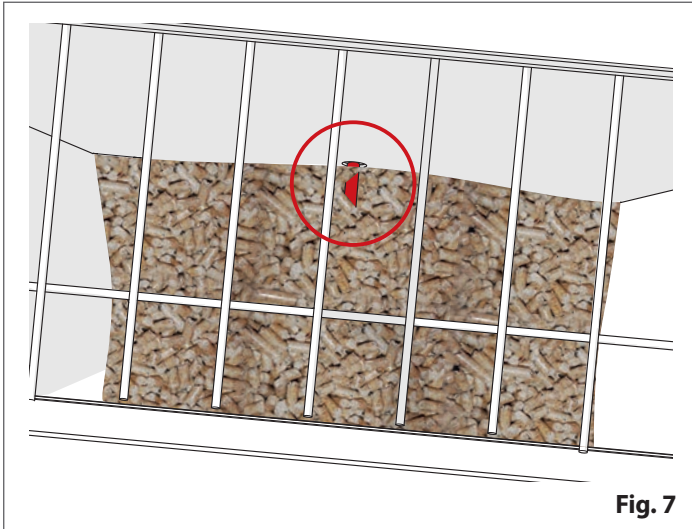

Fig. 7

**!** DO NOT LOAD PELLETS WHEN APPLIANCE IS ON if the red refill indicator is visible inside the pellet tank.

Follow the instructions below if the red refill indicator is visible:

- switch off the appliance
- with the appliance off, reload the hopper

If the auger is even partially emptied, it is probable that the first start-up attempt may fail.

In this case, refer to the manual "*OPERATING INSTRUCTIONS*" in the sections "*FILL AUGER*" and "*MESSAGES - SAFETY WARNINGS - ANOMALIES*".

## 4 GENERAL INFORMATION REGARDING THE SYSTEM

Below is some general information regarding the system, appliance installation and products manufactured by Superior

 Please refer to the installation standards or other informative documentation provided by the manufacturer for further information.

### 4.1 INSTALLATION ROOM

The appliance is to be installed in a room which allows installation, user and maintenance operations to be performed safely and easily.

If the product being installed requires a power socket, the room must also be provided with an earthed power supply in accordance with current regulations.

 Appropriate ventilation in the installation room must be ensured (refer to the section "*FRESH AIR INTAKE*").

- The installation room and the area which is to be heated must be suitable sized and have appropriate characteristics in relation to the heating capacity of the appliance. Compare the information provided in the section "*TECHNICAL DATA*" with the power required by the area which is to be heated.
- If the room or the product installation area (technical room, perimeter walls, recess, supporting walls, etc.) are not suitably insulated, the heating capacity of the appliance will be reduced.
- Consult a heating technician or engineer for a correct check and calculation of the requirement of the environments to be heated and the corresponding regulations.
- The appliance cannot be installed or operated outdoors, only indoors or in suitable technical rooms. Installing the appliance outdoors could create dangerous situations, cause health problems or lead to operating faults.

 Make sure that the floor of the installation room is able to withstand the weight of the product including any cladding, accessories and trim. If the floor does not have a suitable load-bearing capacity, take adequate counter-measures.

- If the flooring is made of wood, provide a floor protection surface in compliance with current national standards.

 Do not install type A and B gas appliances in rooms where there are also heat generators powered by wood (or solid fuels in general) or in adjoining rooms (in line with UNI standards).

- The installation room must not be used to store flammable material.
- The installation room must not be smaller than stated in the regulations and calculated by a specialist heating technician.

#### 4.1.1 Further limitations for NOT airtight installations and installations which do not have combustion air intake from outside

 Information according to UNI standards: please refer to local regulations for clarifications on the restrictions and requirements in your area.

 Installation room:

- must not be a bedroom or a studio flat with the exception of airtight installations or installations of an appliance with a closed firebox with combustion air drawn and ducted directly from outside
- must not be a bathroom, shower room or similar
- it must not have a low pressure compared to the exterior due to a counter draught caused by the presence of another appliance or extractor device in the room where the appliance is installed (eg. forced ventilation systems or other heating systems using ventilation to change the air).

 In the appliance installation room:

- it is not permitted to install liquid fuel appliances with continuous or discontinuous functioning which draw combustion air from the room where the appliance is installed
- simultaneous use of more than one appliance (two stoves or a fireplace and a stove, etc.) is not permitted unless:
  - all provisions indicated by the manufacture of each individual appliance have been respected
  - for heavy simultaneous use, the vacuum measured between the internal and external environment is lower than the value determined by law (4 Pa).



The existence of more than one appliance is only permitted if allowed by the regulations and manufacturer of each individual appliance.

- If the existence of more than one appliance is permitted, all regulations and provisions supplied by the manufacturer of each individual appliance are to be respected.
- C type gas appliances (please refer to legislation in force) are permitted in the installation room of the appliance.

## 4.2 FRESH AIR INTAKE

In order to operate normally, each appliance must be provided with the air needed for combustion.

If a number of appliances are to co-exist, sufficient airflow must be guaranteed for each individual product in full compliance with regulations and according to the manufacturer's indications.

For a question of health, in addition to providing the air flow needed for combustion, it is also recommended that the air inside the installation room is suitably changed.

The airflow needed for the firebox can be obtained in different ways, for example:

- from the installation room or adjacent rooms
- by means of a fresh air intake directly into the room and with ducting
- with a direct connection to the combustion chamber.

In brief, the fresh air intake:

- must guarantee sufficient clean air flow for combustion: air cannot be taken from potentially polluted areas
- must have a total free cross section of at least the value indicated in the section "*TECHNICAL DATA*" and in any case, equal to or greater than the section of the air intake on the appliance
- be protected by a grille or suitable protection which does not reduce the recommended minimum section
- be positioned in such a way that it is not obstructed and maintenance and inspection operations are possible
- must NOT be fitted with manual closing devices that reduce the minimum free cross-section.

### Indications for airtight installations and installations with combustion air intake directly from the outside

Airtight installations must be carried out by connecting the combustion air inlet of the appliance directly to the fresh air intake using a connecting pipe.

The connecting pipe for the combustion air inlet of the appliance must comply with the following requirements:

- have a diameter equal to or greater than the diameter of the inlet on the appliance
- be of a suitable type and made from a non-combustible material
- the pipes, the connectors used and the installation methods must guarantee an airtight seal
- if they are connected directly to the outside, the inlet must prevent atmospheric conditions from negatively affecting the combustion, for example, by means of the installation of a 90° bend at the inlet facing downwards or a shatter-proof guard
- If the installation requires a connection to coaxial type pipes with the inlet of pre-heated combustion air, the materials used must adequately resist the operating temperature.

For the product to operate correctly, the ducting must have the characteristics specified in the section "*COMBUSTION AIR CONNECTION*".

## 4.3 CHIMNEY

Every appliance must be connected to a chimney in order to discharge the combustion gases outside via natural draught.

In brief:

- the chimney must comply with the regulations, bear the CE marking and be made respecting all safety requirements
- the chimney must be suitable for the specific operating conditions of the appliance to be installed and be appropriately sized in relation to the appliance; in particular, it must guarantee the minimum draught specified by the appliance manufacturer
- the chimney must have a soot fire resistance class of G and a minimum temperature class of T400 for wood-fuelled appliances, and T200 for pellet appliances; national installation and construction regulations must be respected (regulations often require a minimum of T400 G)
- the chimney must be attached to one individual appliance, whether that be a stove, a wood-burning stove, etc. unless otherwise specified in the section "*TECHNICAL DATA*" and permitted by national laws and local regulations.

It is recommended that the chimney has a chamber for collecting solid matter and any condensate below the connection and which may be easily opened and inspected by means of an airtight door

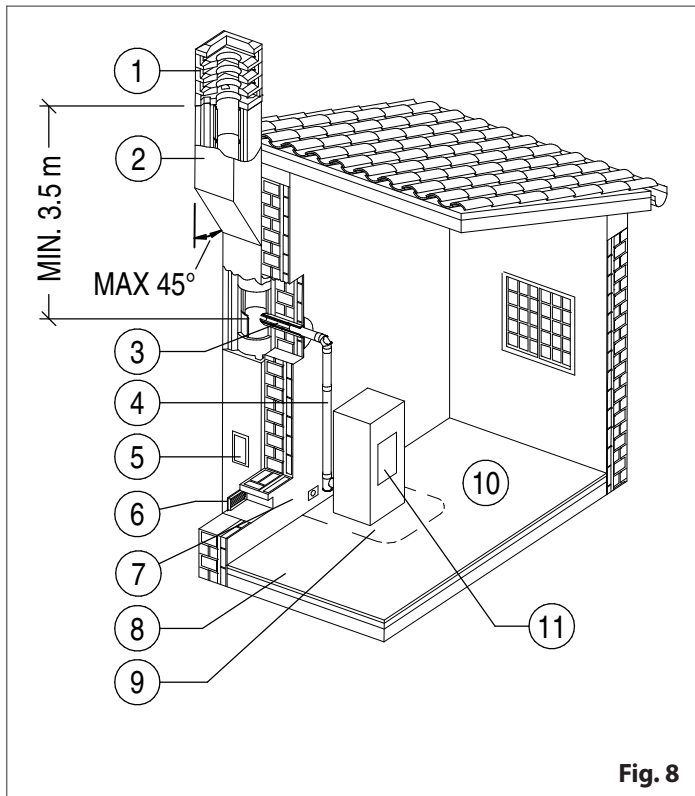

Fig. 8

- 1 Chimney terminal
- 2 Flue
- 3 Connection to the flue
- 4 Flue pipe
- 5 Soot inspection
- 6 Fresh air intake
- 7 Electrical supply
- 8 Check the load bearing capacity of the floor
- 9 Minimum safety distances
- 10 Installation environment
- 11 Appliance (Heat generator)

If the chimney does not meet the requirements, consult with specialised personnel regarding adjustment of the current chimney, for example, by providing adequate piping.

**⊘** The connection for the combustion product outlet must comply with local regulations.

- In Italy and other European countries combustion products must be discharged through the roof and it is forbidden to discharge combustion products directly on the wall or towards closed spaces even if in the open air.
- Please refer to local regulations for clarifications on the restrictions and requirements in your area.

#### 4.4 CHIMNEY TERMINAL

The chimney terminal is the part which is positioned on the top of the flue to ease the dispersion of combustion products into the atmosphere.

In brief, remember that the chimney terminal:

- must have a useful outlet section of not less than twice that of the flue
- must be built in such a way as to prevent the penetration of rain, snow and foreign matter into the chimney

- must be constructed in such a way as to ensure that in the event of winds from all directions and angle, discharge of the combustion products is assured (chimney terminal with anti downdraught cowl)
- must be positioned outside the reflux area
- must be positioned taking into account the roof inclination and respect the distances in relation to buildings, plants, aerials or other obstacles as prescribed by regulations.

#### 4.5 FLUE PIPE

Connecting flue pipe indicates the set of components which connect the appliance to the flue.

**⚠** Distance (F): for information regarding the safety distances, installation methods, maintenance, safety and insulation, please refer to the indications attached provided by the connecting flue pipe manufacturer.

- The minimum distance (F) from heat-sensitive construction elements or combustible materials must be respected along the entire length of the flue pipe (for example, fabric, clothing, cladding, walls, and wooden beams or ceilings.), furthermore, when a pipe passes through a wall or ceiling, particular installation methods must be applied.
- In order to ensure safety where there may be the risk of accidental contact with the connecting flue pipe, the external surface must be sufficiently protected in compliance with regulations and instructions provided by the connecting flue pipe manufacturer.

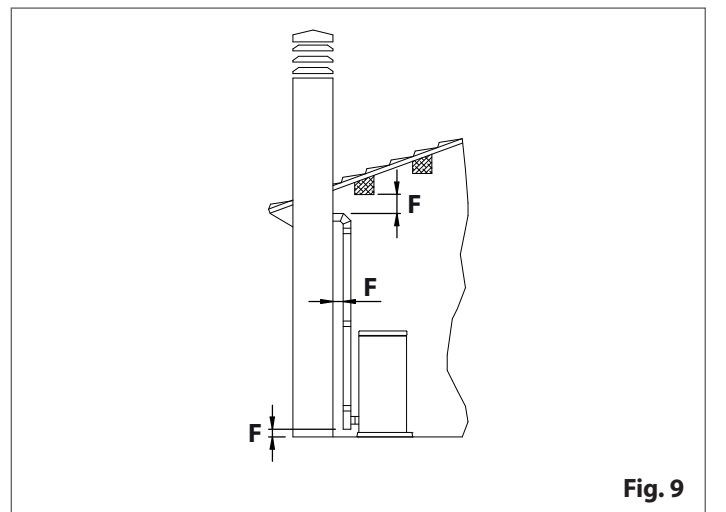

Fig. 9

**⊘** The connecting flue pipe must not cross rooms where it is prohibited to install combustion appliances, nor in other rooms divided into compartments for fire or with the hazard of fire, or in rooms and/or spaces that cannot be inspected.

- It is forbidden to install hoses or pipes made of metal or fibre cement, pipes which do not have CE approval and the use of elements with reverse slope.
- In forced ventilation products (for example pellet stoves), it is forbidden to install grates or valves which may obstruct the exhaust smoke passage.



In particular, remember that the connecting flue pipe:

- must be in compliance with regulations, equipped with CE marking and be made respecting all safety requirements
- must be suitable for the specific operating conditions of the appliance to be installed and appropriately sized in relation to the appliance; in particular, it must guarantee the minimum draught specified by the appliance manufacturer
- must be airtight and tight to all combustion products
- must be installed so as to allow normal thermal expansion and be self supporting so as not to inflict its weight on the smoke outlet. If this is not the case, secure it with appropriate supports
- must be secured to the chimney intake so as not to obstruct the exhaust smoke passage; furthermore, the end section of the intake and the chimney axis must intersect
- it is recommended that it is equipped with inspection apertures so that periodic cleaning and maintenance operations can be carried out without the need for completely disassembling the duct
- must have a diameter, along the entire length, no less than that of the appliance outlet.

**Additional requirements for the connecting flue pipe**

To ensure correct product operation, where not specified under items "TECHNICAL DATA" and "CONNECTION TO THE SMOKE OUTLET", the connection to the flue pipe must have the following characteristics:

length of the connecting flue pipe (a)	maximum 6 m
length of the connecting flue pipe projecting horizontally (b)	maximum 4 m
length of the first horizontal section (d) of the connecting flue pipe, connected to the appliance directly or by means of a "TEE" connector or elbow connector (1)	maximum 1 m
number of direction changes (c) not greater than 90° including the one relating to the connection of the appliance to the chimney (2)	maximum 3
diameter of the connecting flue pipe for appliances with rated heat output ≤ 13 kW	minimum 80 mm (3)
diameter of the connecting flue pipe for appliances with rated heat output > 13 kW	minimum 100 mm (3)

- (1) in this case, after the horizontal section (d), there must be a direct insertion of the flue pipe or a vertical section (e) of the connecting flue pipe with a minimum length of 1.5 m.
- (2) if the smoke outlet on the appliance has a horizontal axis, the direction change (t) resulting from the connection to the appliance (by means of a "TEE" connector or an elbow connector) is not counted.
- (3) diameter no less than that of the appliance outlet.

Some systems – particularly those with appliances equipped with a boiler – may cause condensation to form, even if you abide by the indications provided.

If this occurs, adopt the following measures:

- shorten the connecting flue pipe
- for class D (not humidity-resistant) flues/chimneys/connecting flue pipes, insulate as appropriate (as per regulations)
- use class W (humidity-resistant) flues/chimneys/connecting flue pipes
- use double-walled flues/chimneys/connecting flue pipes

**i** For information on the position of the smoke outlet of your appliance, refer to the section "DIMENSIONS" and "CONNECTION TO THE SMOKE OUTLET".

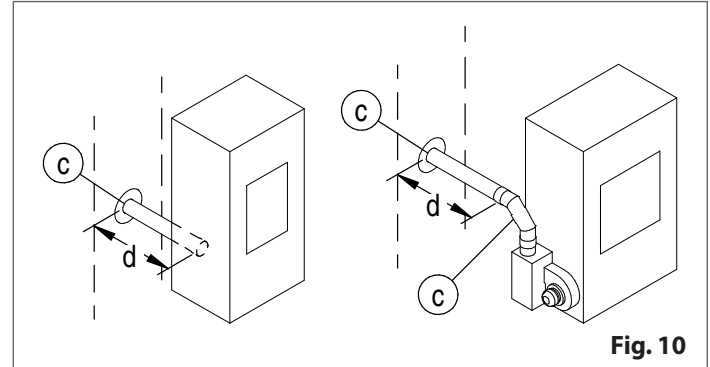

Fig. 10

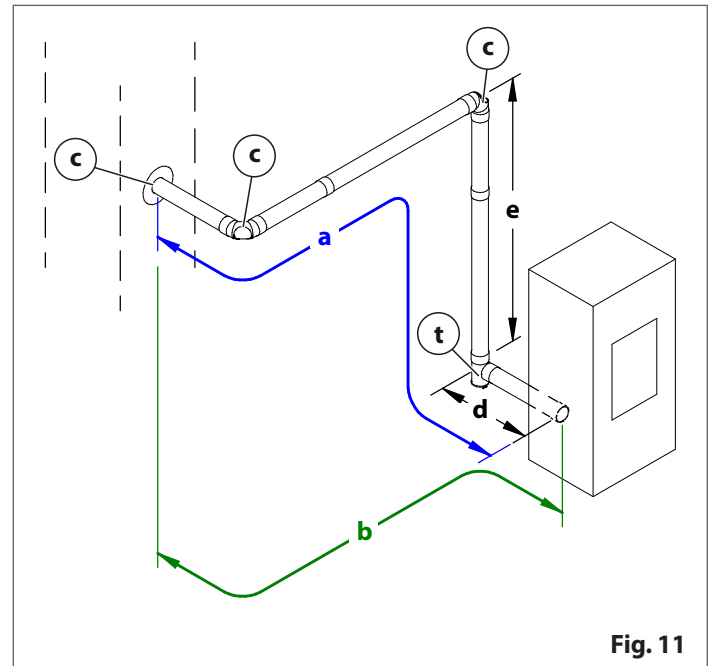
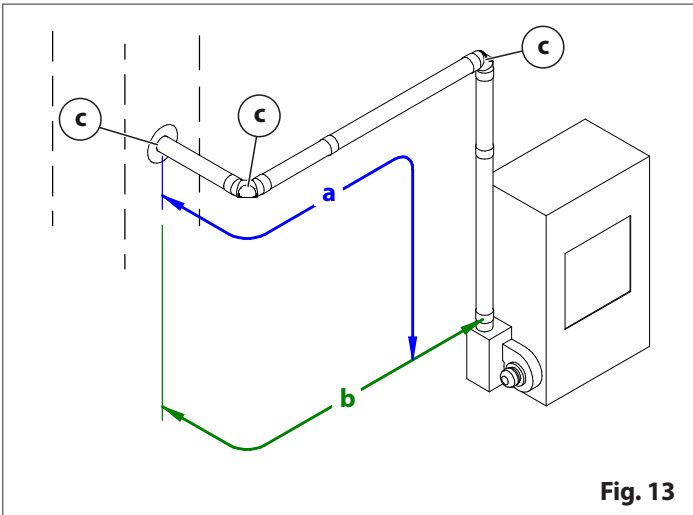
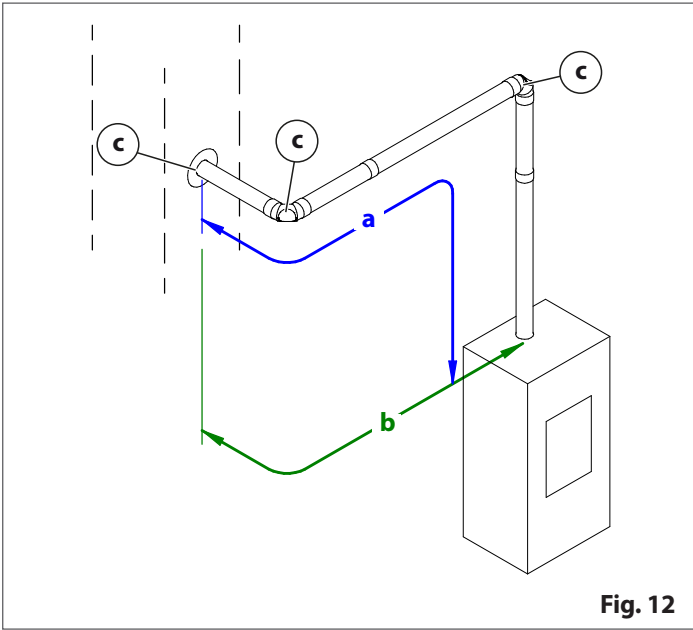

Fig. 11



## 5 PREPARATIONS FOR INSTALLATION

- !** Product installation and maintenance must be carried out exclusively by qualified personnel with sufficient knowledge of the product itself.
- This work must also be carried out using suitable equipment and in full compliance with all health and safety regulations.

### 5.1 HANDLING

In order to prevent any accidents or damage to the product, please follow the recommendations below.

- Unpacking and installation must be carried out by at least two people
- the product must always be moved and handled with suitable equipment in full compliance with current safety regulations
- wear suitable personal protective devices (gloves, safety shoes, etc.)
- the packaged product must be kept in the position according to the directions shown by the diagrams and signs on the pack
- if using ropes, webbing, chains, etc., make sure that they are suitable for the weight to be unloaded, are in good condition and suitably protect the product at the contact points
- use slow continuous movements when moving the pack to avoid jerking the ropes, chains etc.
- do not tilt the package excessively to avoid toppling
- never stand in the vicinity of loading/unloading equipment (forklift trucks, cranes etc.).

When handling any steel parts of the cladding it is advisable to use clean cotton gloves to avoid leaving fingerprints which are difficult to remove at first time of cleaning.

### 5.2 UNPACKING

- !** When unpacking and removing the packaging material, make sure the product is not scratched or damaged.
- Do not leave parts of the packaging where they are within the reach of children as they could be dangerous. Dispose of them according to legislations currently in force.
  - Remove the accessories' packaging and any pieces of polystyrene or cardboard used to secure removable parts, etc. from the firebox.

After having removed the material protecting the appliance, remove all the retainers securing the appliance to the pallet and then remove it from the pallet.

- !** Make sure that while working, the lower parts of the side panels and the lower front panel do not get misshapen, scratched or damaged.

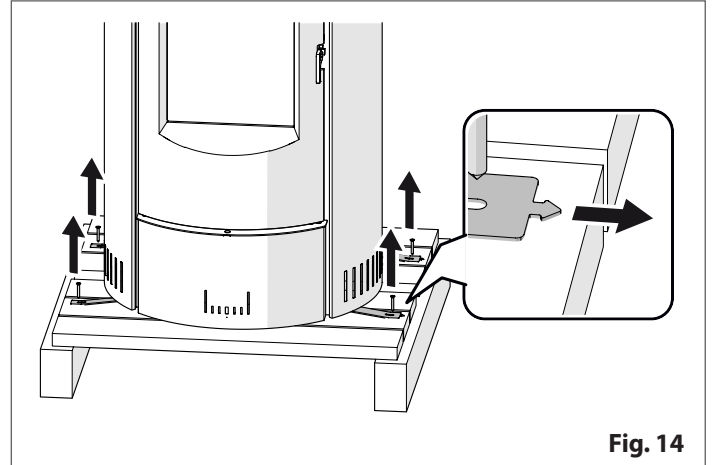

Fig. 14

### 5.3 ACCESS TO THE INTERNAL PARTS OF THE PRODUCT

#### Top surface

Proceed as follows:

- open the pellet hopper cover (1)
- remove the screws (2)
- remove the top surface panel (3)

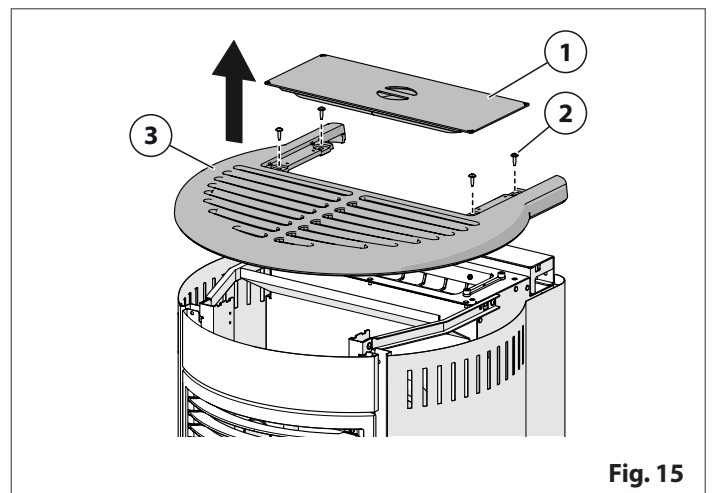

Fig. 15

**Side panels**

Proceed as follows:

- open the firebox door
- loosen the screws (1)

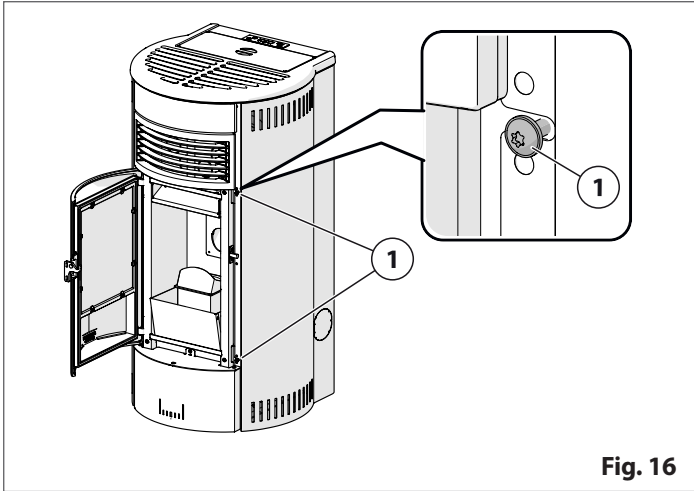

Fig. 16

- loosen the screws (2)
- remove the panel (3)

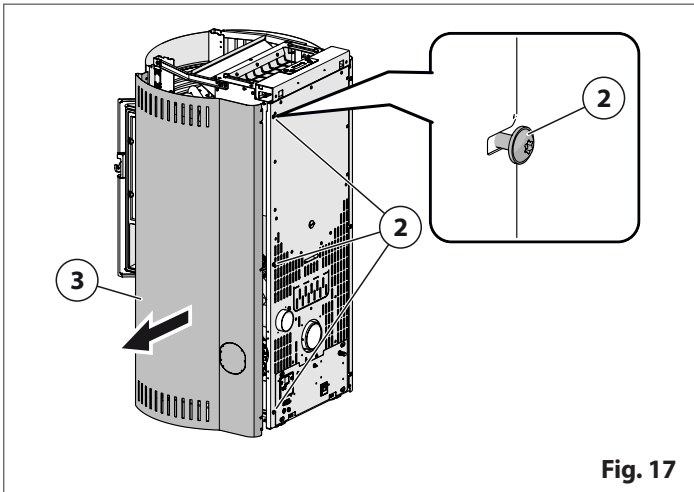

Fig. 17

**Lower front panel**

Proceed as follows:

- open the firebox door
- remove the screws (1)
- remove the lower panel (2)

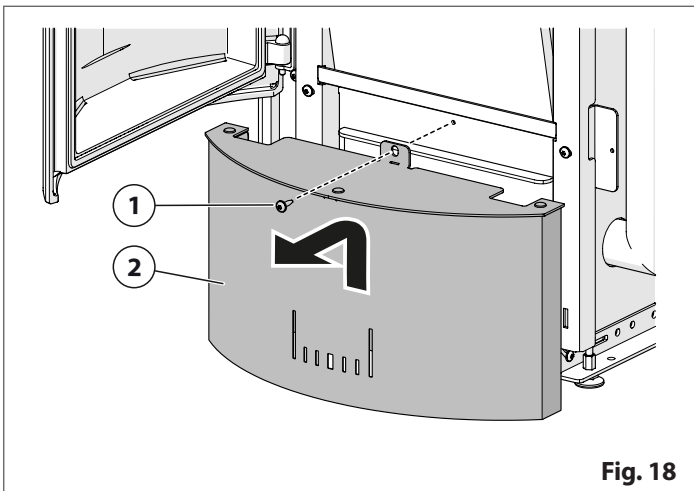

Fig. 18

**6 INSTALLATION**

**!** For all installation and maintenance interventions which require access to inside the cladding, the smoke chamber or access to electrical and electronic parts, the user must contact a T.A.C. (Technical Assistance Centre) or qualified technician.

- All installation, cleaning and maintenance work is to be carried out when the fire is out, the appliance is cold and with the power cable of the product itself and/or any other accessories disconnected.
- This work must also be carried out using suitable equipment and in full compliance with all health and safety regulations.

**6.1 MINIMUM SAFETY DISTANCES**

The position of the product inside the room must take into account not only the regulations, heating requirements, the shape of the installation and adjoining rooms but also accessibility during installation, use and maintenance operations.

It is therefore recommended that an area greater than the one indicated, is left around the appliance to facilitate maintenance interventions and prevent overheating problems.

The walls adjacent to the product, the structure above the appliance and the floor on which the appliance rests must be in non-combustible material.

The appliance can be installed next to heat-sensitive or combustible materials as long as suitable insulating protection is used and the minimum clearance distances are respected: should the surface the appliance is rested on be made from a combustible material (e.g. wooden flooring), use a protective base (e.g. a sheet of steel plate, marble, tiles, stone, brick, etc.) and a thermal insulation shim (where required).

Construction elements which are already present such as wooden beams or a counter-hood and all trims in combustible material must be positioned outside the irradiating range of the product and away from any grilles or slits from which hot air is released. Suitable insulating material must be used.

**!** The product must be installed in compliance with the appropriate safety distances from the walls and objects. Failure to comply with these indications could result in fire.

**!** Keep any combustible or heat-sensitive products such as wooden furniture, curtains, carpets, fabric, clothing, ornaments and flammable liquids well away from the product while it is in operation (where not indicated, minimum of 100 cm).

**i** Please refer to the section "TECHNICAL DATA" and installation instructions for the values.

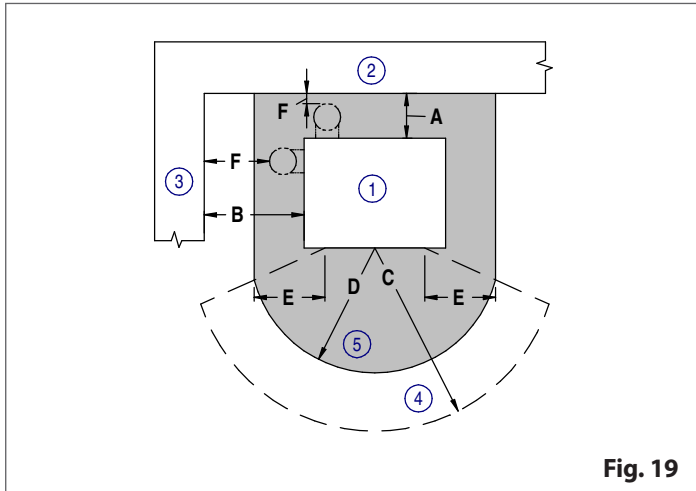

Fig. 19

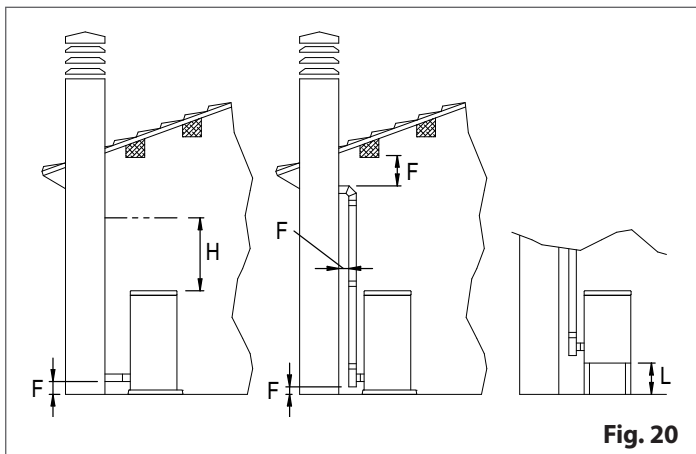

Fig. 20

- 1 Appliance (heat generator)
- 2 Rear wall
- 3 Side wall
- 4 Radiant area of the fireside opening
- 5 Floor protection
- A Product air distance from rear wall
- B Product air distance from side walls
- C Area free from combustible or heat-sensitive materials
- D Distance of front floor protection overhang
- E Distance between inside edge of firebox opening and the edge of the floor protection
- F Air distance of the connecting flue pipe from the other elements
- H Distance clear from top edge of product
- L Air distance from the floor

**!** Distance (F): for information regarding the safety distances, installation methods, maintenance, safety and insulation, please refer to the indications attached provided by the connecting flue pipe manufacturer.

- The minimum distance (F) from heat-sensitive construction elements or combustible materials must be respected along the entire length of the flue pipe (for example, fabric, clothing, cladding, walls, and wooden beams or ceilings.), furthermore, when a pipe passes through a wall or ceiling, particular installation methods must be applied.
- In order to ensure safety where there may be the risk of accidental contact with the connecting flue pipe, the external surface must be sufficiently protected in compliance with regulations and instructions provided by the connecting flue pipe manufacturer.

## 6.2 COMBUSTION AIR CONNECTION

**!** Please refer to and carefully read the section "FRESH AIR INTAKE".

### Indications for the connecting pipe

It is recommended that a connection test is carried out before sealing and securing the various elements.

It is also recommended to:

- make the path as short and as straight as possible
- avoid unnecessary bends
- avoid any contact with hot parts, even unintentional contact (for example smoke outlet pipe)
- calculate beforehand the length of the connecting path then take a flexible pipe which is longer than necessary and can be cut to the correct length during the final phase
- secure the flexible pipe using a clamp and/or appropriate seal to make it airtight.

For the product to operate correctly, the ducting must have the following characteristics:

minimum diameter	60 mm	
maximum number of direction changes not greater than 90° (including first connection to appliance)	2	3
maximum ducting length	2 m	1,5 m

### 6.3 CONNECTION TO THE SMOKE OUTLET

**!** Please refer to and carefully read sections "FLUE PIPE" and "MINIMUM SAFETY DISTANCES".

- The flue pipe must allow normal thermal expansion and must not weigh down on the product's flue outlet. It must be self-supporting and secured in place with appropriate supports.

The appliance is equipped as standard with the smoke outlet (1).

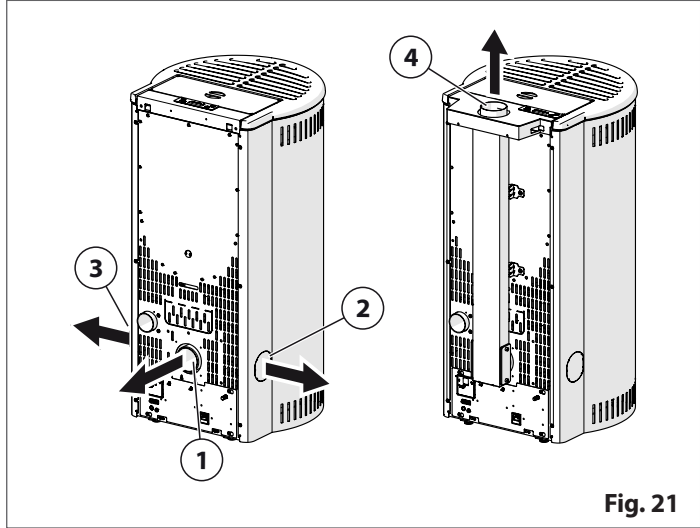

Connection to other outlets is possible:

- left smoke outlet (2) \*
- right smoke outlet (3) \*
- upper smoke outlet (4) \*

(\* Purchase the specific smoke outlet connector (accessories).

**i** For the installation of any KIT and ACCESSORIES, please refer to the instructions provided with the kits or accessories.

#### Additional requirements for the connecting flue pipe

Superior supplies pipes and bends for the connecting flue pipe, all of which are approved and specifically sized for the smoke outlet of its products.

Pipes approved by other manufacturers may also be applied as long as they have been appropriately adjusted, compatibility with the coupling has been checked and they comply with regulations.

In this case however, Superior can only ensure good operation for the products it manufactures or that it has tested and recognized and providing that installation and use comply with all specifications and regulations.

In the event pipes with a diameter greater than that of the appliance outlet are used, connect with an appropriate adapter (which is not supplied by Superior).

**!** It is recommended that elements with inspection apertures are used to facilitate periodic checks and cleaning of the connecting flue pipe.

#### "TEE" connector

For good operation it is recommended that a "TEE" connector (1) is fitted to the smoke outlet of the appliance, or at the first change of direction of the connecting flue pipe as this allows the condensation to be collected, mixed with the soot which deposits on the inside of the pipe, and the first section to be periodically cleaned without having to disassemble the pipes.

This connector can be purchased from the dealer together with the pipes for the connecting flue pipe..

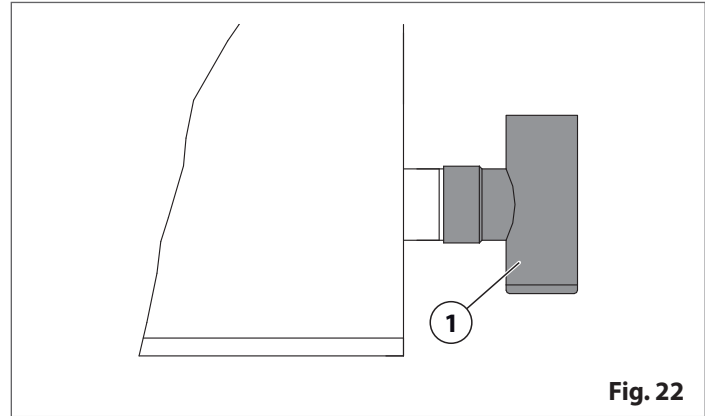

### 6.4 ELECTRICAL CONNECTIONS

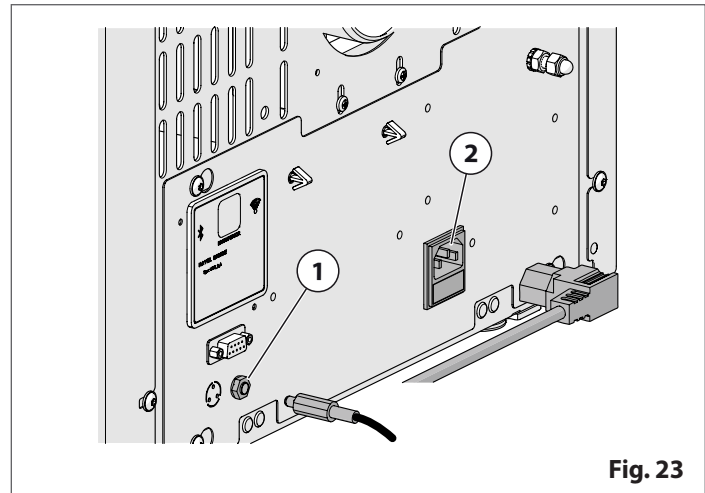

- 1 Room probe connection
- 2 Power cable socket

**!** Electrical work must be carried out by qualified technicians.

- The electrical cables MUST NOT come into contact with hot or moving parts.

### 6.4.1 Power cable

The appliance comes supplied with a power cable which must be connected to a 230V~50Hz socket.

**!** The appliance must be connected to an effective earthing system.

- Ensure that the power cable, in its final position, does not come into contact with hot parts.
- The plug must be connected only AFTER installation is complete and the appliance has been assembled. It must be accessible after installation.

### 6.4.2 Room temperature probe

Connect the room temperature probe provided to the designated connector on the appliance. The bulb of the probe must be in a position which allows the most accurate reading of the room temperature to be taken.

**i** If the probe is not connected, an acoustic signal is given (refer to the manual "OPERATING INSTRUCTIONS" in the section "MESSAGES - ALARMS - ANOMALIES").

### 6.4.3 External environment thermostat

The appliance allows for connection to an external thermostat (not supplied as standard). This allows operation to be determined on the basis of the room temperature detected by the thermostat.

**!** Consent must come from a non-powered contact. Do not connect any powered element.

**i** For information regarding operation, please refer to the manual "INFORMATION REGARDING OPERATION" in the section "EXTERNAL THERMOSTAT".

**i** Use a 2x0,22 mm<sup>2</sup> cable to make the connection.

For installation:

- the appliance must NOT be connected to the electrical power supply
- remove the right panel (refer to the section "ACCESS TO THE INTERNAL PARTS OF THE PRODUCT")
- connect the cable (2) to the external device (1)
- remove the knockout (3)
- install a PG7 cable gland or one with a suitable diameter (not provided as standard) in the hole (3)
- pass the other end of the cable through the cable gland PG7 and connect it to the 2 PIN terminal (5) supplied as standard
- insert the terminal into its own seat on the board (4)
- replace all the components in the reverse order.

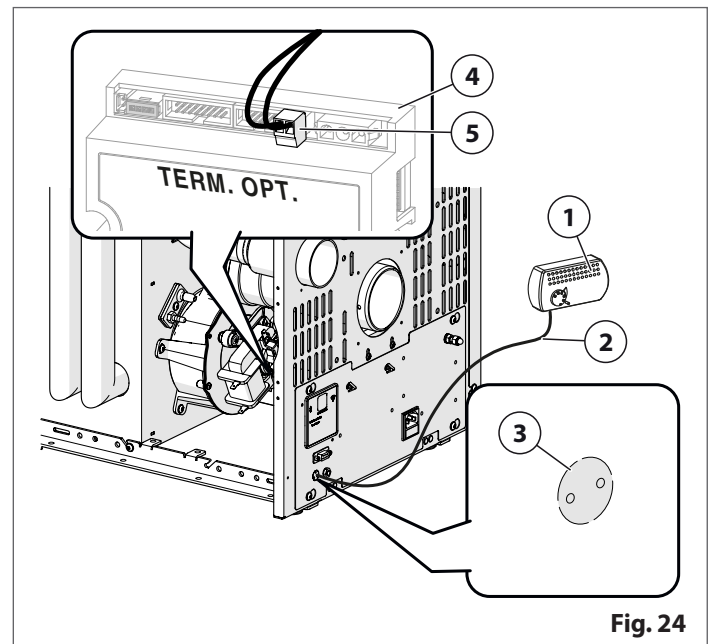

#### 6.4.4 Alarm contact

The alarm connection is used to connect up an external safety device, which may be required by local law to prevent the appliance from functioning in the event of a fault.

**i** Only connect devices approved by Superior. For more information on installation and operation, please contact a T.A.C. (Technical Assistance Centre) or qualified technician.

**!** Consent must come from a non-powered contact. Do not connect any powered element.

**i** For information regarding operation, please refer to the manual "*INFORMATION REGARDING OPERATION*" in the section "*ALARM CONTACT*".

**i** Use a 2x0,22 mm<sup>2</sup> cable to make the connection.

For installation:

- the appliance must NOT be connected to the electrical power supply
- connect the cable (1) to the external device
- access the electronic control unit (3)
- connect the ends (2)

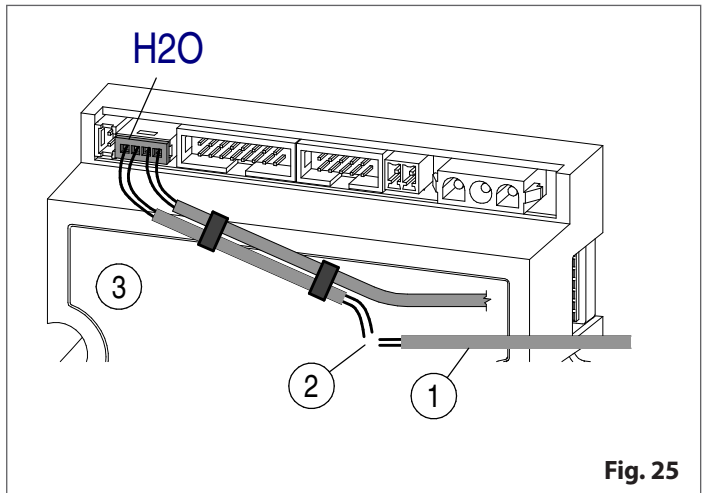

Fig. 25

## 7 START-UP AND OPERATING TEST

A start-up and operational test must be carried out by a specialized qualified technician to check that the appliance and all other connected system elements operate correctly. It is therefore understood that depending on whether heating is via air or water, the hot air ducts present or the hydraulic circuit are to be checked along with other connected heat sources.

**i** Find out the cost of these operations from the specialised technician.  
 ■ Refer to the manual "*OPERATING INSTRUCTIONS*".

## 8 CLADDING AND TRIM

When installation has been completed, in addition to the indications given above, it may be necessary to fit accessories such as external cladding, parts and trims.

**i** Please follow indications provided in the section "*START-UP AND OPERATING TEST*":  
 ■ before completing the cladding assembly operations  
 ■ after all cladding and construction interventions have been completed.

## 9 USE

**i** For information regarding operation, please refer to the manual "*OPERATING INSTRUCTIONS*".



## 9.1 HUMIDIFIER (ACCESSORIES)

The appliance is equipped with a system to humidify the environment (accessories).

**i** The humidifier is to be filled with water on average every two or three days and in any case, on the basis of appliance use.

**!** Do not fill the humidifier beyond the level marked "MAX". If any water were to leak out, it could damage the appliance.

- Refilling operations are to be carried out with the fire out and when the appliance has cooled down completely.
- The humidifier is to be cleaned with the fire out, with the appliance off and disconnected from the electrical power source.

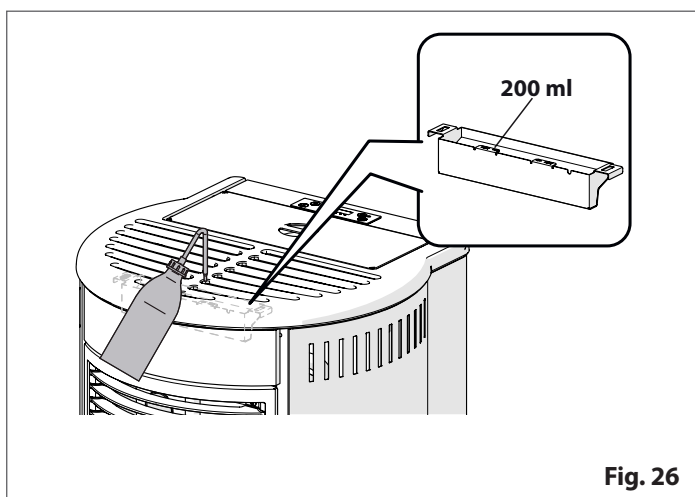

Fig. 26

Proceed as follows:

- open the pellet hopper cover (1)
- remove the screws (2)
- remove the top surface panel (3)
- position the humidifier (4)

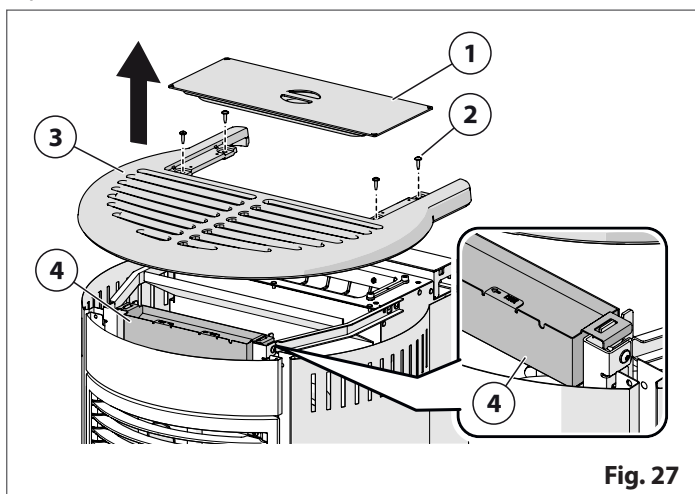

Fig. 27

**!** Make sure that the product does not get scratched or damaged.

## 10 CLEANING AND MAINTENANCE

**!** For all installation and maintenance interventions which require access to inside the cladding, the smoke chamber or access to electrical and electronic parts, the user must contact a T.A.C. (Technical Assistance Centre) or qualified technician.

- All installation, cleaning and maintenance work is to be carried out when the fire is out, the appliance is cold and with the power cable of the product itself and/or any other accessories disconnected.
- This work must also be carried out using suitable equipment and in full compliance with all health and safety regulations.

**!** After installation, cleaning and maintenance work:

- restore and replace all worn or damaged parts with original spare parts
- restore all initial connections together with the normal operating conditions of the appliance and the system
- carry out a start-up and operating test to check that there are no faults.

Maintenance interventions are mandatory in order to ensure safety, for correct and efficient stove operation and to guarantee a long life of operation. If maintenance is not carried out with the recommended frequency, appliance performance could suffer and/or malfunctions could occur.

**The manufacturer will not be responsible for appliance deterioration or malfunction if due to poor maintenance.**

**i** Cleaning must be carried out with suitable equipment and in full compliance with all health and safety regulations.

- The materials and equipment used for cleaning must not alter appliance characteristics or operation in any way.
- The disposal of waste resulting from cleaning operations must be in full compliance with current laws and regulations on waste disposal.

## 10.1 SCHEDULED MAINTENANCE

 Scheduled maintenance must be carried out at least ONCE A YEAR and in any case, before the commissioning of the appliance after a long period of inactivity.

 The time intervals are merely an indication: these intervals may need to be shorter depending on the frequency of use and the type of fuel used.

 After installation, cleaning and maintenance work:

- restore and replace all worn or damaged parts with original spare parts
- restore all initial connections together with the normal operating conditions of the appliance and the system
- carry out a start-up and operating test to check that there are no faults.

The following interventions are included in maintenance:

- checking the components for wear and ensuring they are integral and operate correctly
- checking there is no dirt, dust, deposits or obstructions
- checking that all components are positioned and secured correctly
- replacing damaged or worn components
- cleaning
- all interventions needed to ensure correct operation provided they are carried out in compliance with regulations.

Recommended interval	
<b>Interventions which may be carried out by the user</b>	
Glass	1 day
Brazier and grate support	1 day
Ash drawer (if present)	2 days
Area behind the cladding panels (if there are no electrical components or moving electro-mechanical elements)	1 year
Remote control batteries (if present)	1 year
<b>Operations which require the intervention of the T.A.C.</b>	
Smoke chamber	1 year
The smoke outlet	1 year
Smoke outlet system	1 year
Fresh air intake and combustion air pipe	1 year
Ventilation system: vents, air ducting, grilles (if present)	1 year
Extractor fan	1 year
Room fans (if present)	1 year
Electrical parts and electronic components (if present)	1 year
Tightness and condition of the seals around the glass and all elements which are subject to wear	1 year
Area behind the cladding panels (if there are electrical components or moving electro-mechanical elements)	1 year
Replacing the fuses (where inside the cladding)	

## 10.2 CLEANING THE PAINTED METAL PARTS

When cleaning the painted metal parts, use a soft cloth moistened with water.

 Do not clean metal parts using alcohol, solvents, petrol-based products, acetones or other degreasing or abrasive substances. In the event of such substances being used, the manufacturer cannot be held responsible for any damage caused.

Discolouration of metal parts may be the result of misuse.

### 10.3 OPENING THE DOOR

Use the fire door opening tool, which is supplied as standard, to open the door as follows:

- take hold of the fire door opening tool (1)
- insert and hook the fire door opening tool onto the handle (2)
- rotate the handle upwards.

It will now be possible to clean the inside of the glass or carry out appliance maintenance.

**!** The door must remain closed while the appliance is operating. The door may only be opened when the appliance is off and cold.

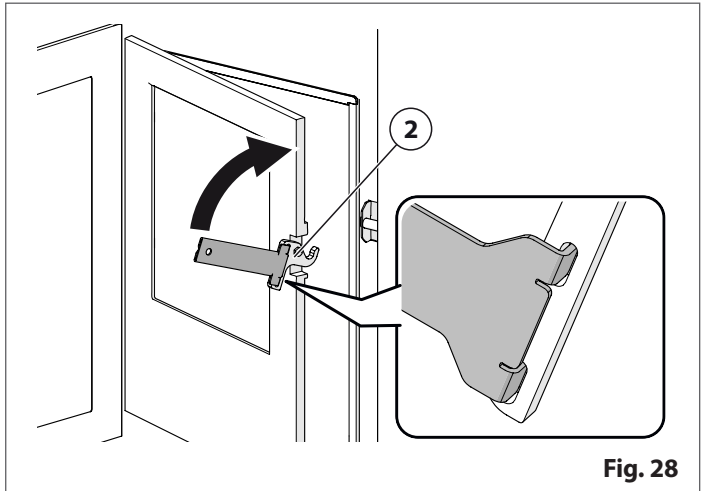

Fig. 28

### 10.4 CLEANING THE GLASS

During start-up it is possible that tar may accumulate on the glass which will disappear when optimal combustion is reached. If this does not happen, it is recommended that the glass is cleaned daily, before start-up, to prevent the formation of any deposits which would be difficult to remove.

**i** Recommended cleaning frequency: refer to the section "SCHEDULED MAINTENANCE".

**!** The glass should be cleaned when cold using ammonia-based non-corrosive degreasing agents (for example, do not use solvents).

- Do not use any material that could scratch or spoil the glass, as scratches may develop into cracks or breaks.

### 10.5 DISPOSAL OF ASHES

Ash from natural (non-treated) wood burned in stoves or open fireplaces is composed mainly of calcium, silicon, potassium and magnesium. For this reason, it may be used as a fertilizer for plants, as long as 2.6 kg/10m<sup>2</sup> is not exceeded annually.

**!** The ashes should be placed in a metal container with a sealed cover. The sealed container should be placed on a non-combustible surface at a safe distance from combustible materials until the cinders have completely extinguished.

- Only when they have been fully extinguished can the ashes be thrown away with organic waste, assuming that non-organic materials are not present.

**⊘** Do not throw live cinders into waste containers.

### 10.6 CLEANING THE ASH TRAY

**i** Recommended cleaning frequency: refer to the section "SCHEDULED MAINTENANCE".

- To dispose of the ash, please refer to the section "DISPOSAL OF ASHES".

Proceed as follows:

- remove the ash drawer (1)

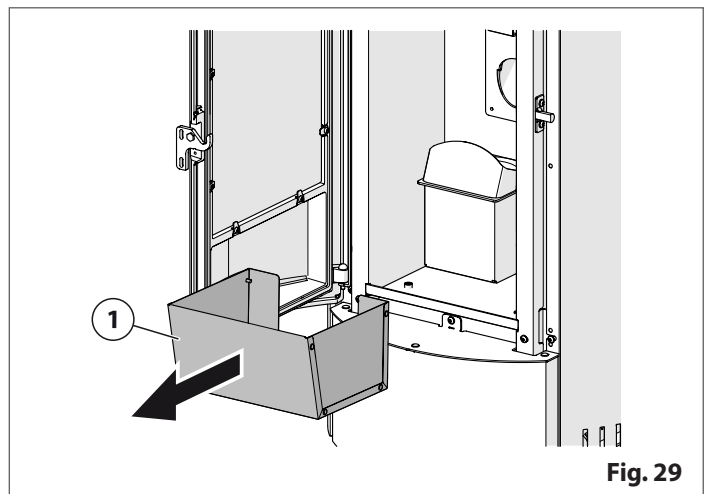

Fig. 29

## 10.7 CLEANING THE GRATE AND GRATE SUPPORT

The grate area must be cleaned.

- i** Recommended cleaning frequency: refer to the section "SCHEDULED MAINTENANCE".
- Before proceeding to start-up, any unburned pellets which are in the grate must be removed. Do not reverse unburned pellet in the hopper.

Proceed as follows:

- open the firebox door
- remove the grate deflector (1)
- release the grate (2) from its housing
- remove any ash and deposits which may have formed, making sure that any clogged holes are cleared
- keep the grate "start-up hole" (3) clean
- check the grate support (4) and remove any ash present
- using a vacuum cleaner suitable for cleaning ash, remove all the residue which has deposited on the walls in the combustion chamber
- reposition the grate into its original position pushing it towards the start-up hole
- reposition the grate deflector.

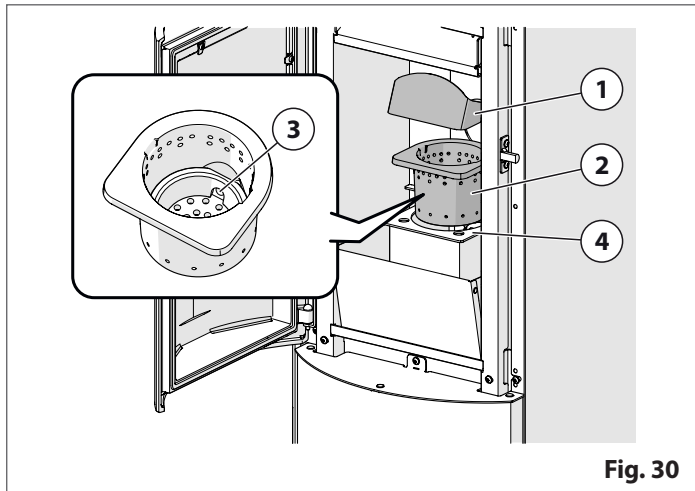

Fig. 30

- !** Before turning on the appliance, check that the grate is positioned correctly in its seat (and pushed towards the start-up hole).
- A vacuum cleaner which is suitable for use with ash is needed when carrying out this type of cleaning operation.

- i** To dispose of the ash, please refer to the section "DISPOSAL OF ASHES".

## 10.8 CLEANING THE SMOKE CHAMBER

- i** Recommended cleaning frequency: refer to the section "SCHEDULED MAINTENANCE".
- This operation facilitates an optimal heat exchange and better product performance.

Proceed as follows:

- carry out the operations indicated under "CLEANING THE GRATE AND GRATE SUPPORT"
- remove the deflectors (1) one at a time by turning the lower part outwards

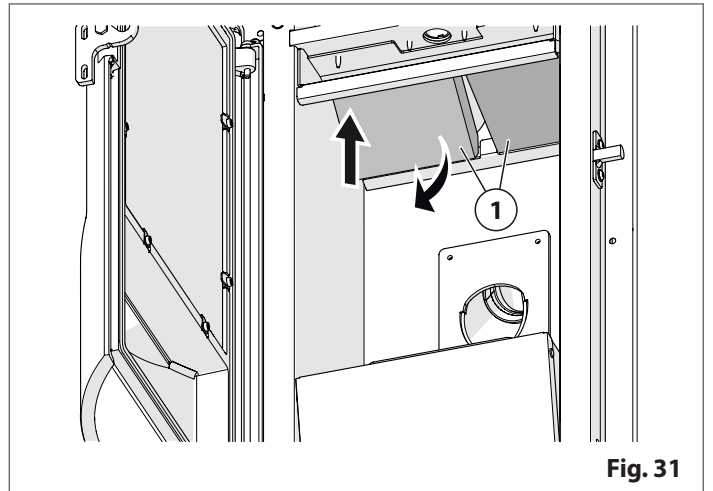

Fig. 31

- clean the full duct (A) using the pipe cleaning brush provided (B)

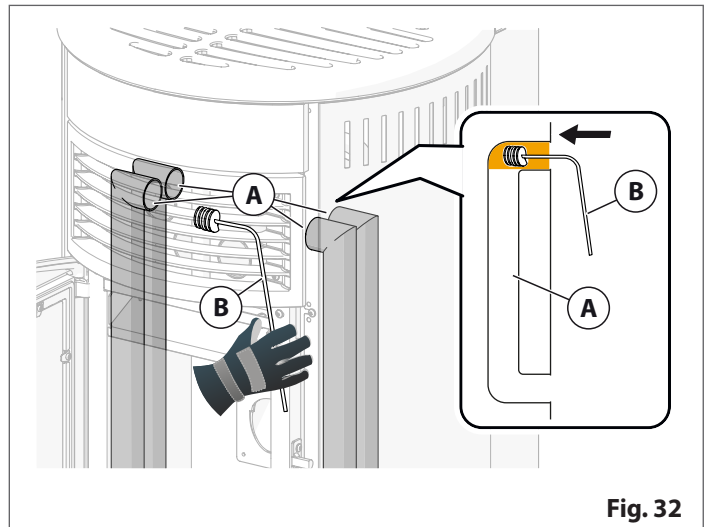

Fig. 32

- using a vacuum cleaner suitable for cleaning ash, remove all the residue which has deposited on the side walls and in the upper part of the firebox
- clean the parts which have been removed and then refit them in the reverse order in which they were removed.

Proceed as follows:

- remove the screw (1)
- remove the lower panel (2)
- unscrew the screws (3) and remove the cover (4)
- remove the gasket (5)

**!** Make sure that the product does not get scratched or damaged.

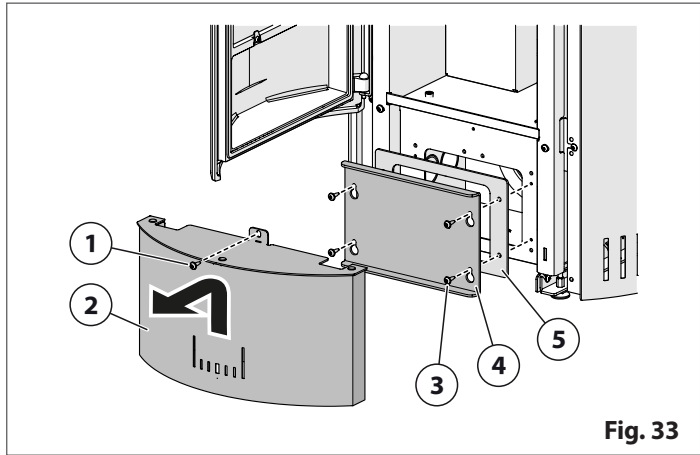

Fig. 33

- clean the full duct (A) using the pipe cleaning brush provided (B)

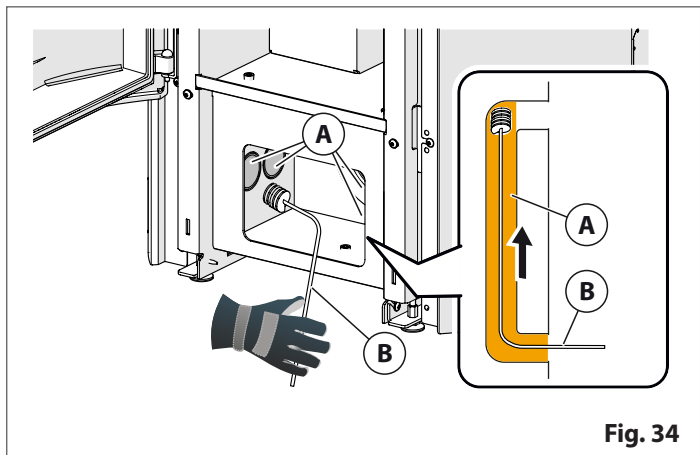

Fig. 34

- using a vacuum cleaner suitable for cleaning ash, remove all the residue which has deposited on the walls in the smoke chamber
- clean around the extractor smoke fan (C).

**!** Make sure that the extractor fan blade is not damaged in the process.

- clean the hole for the vacuum detection (D) inside the smoke chamber as indicated in the figure: for the appliance to operate correctly, the hole must always be free of dust and ash

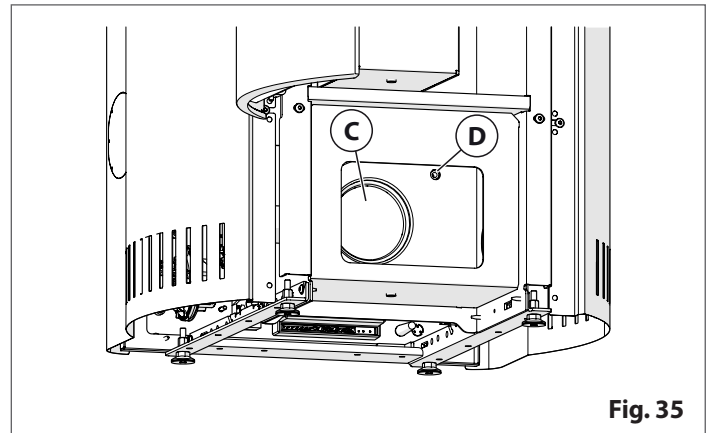

Fig. 35

**!** Check that the seal is not worn and seals correctly.

- reposition the gasket (5)
- reposition the cover (4)
- screw in the screws (3)
- remove all the ash present inside the appliance
- reposition the lower panel (2)
- screw in the screw (1)
- close the firebox door.

**!** A vacuum cleaner which is suitable for use with ash is needed when carrying out this type of cleaning operation.

- A suitable ramrod may need to be used in order to remove any stubborn deposits.

**i** To dispose of the ash, please refer to the section "DISPOSAL OF ASHES".

### 10.9 CLEANING THE EXTRACTOR FAN

Any dust or ash deposits on the smoke extractor fan blades may result in the fans becoming noisy when the appliance is in operation. It must be cleaned.

**i** Recommended cleaning frequency: refer to the section "SCHEDULED MAINTENANCE".

**!** Cleaning must only be carried out by a T.A.C. (Technical Assistance Centre) or a qualified technician.

### 10.10 CLEANING THE ROOM FAN

Any dust deposits on the fan blades may make the fans noisy during operation. It must be cleaned. It is recommended that any deposits which may have formed in the hot air outlet grilles are also removed.

**i** Use a vacuum cleaner or compressed air cleaner for this.  
 ■ Recommended cleaning frequency: refer to the section "SCHEDULED MAINTENANCE".

**!** Cleaning must only be carried out by a T.A.C. (Technical Assistance Centre) or a qualified technician.

To access the room fan, please refer to the section "ACCESS TO THE INTERNAL PARTS OF THE PRODUCT".

- it is recommended that an ash vac and a soft brush is used
- make sure the internal fan does not get damaged
- clean the parts which have been removed and then refit them in the reverse order in which they were removed.

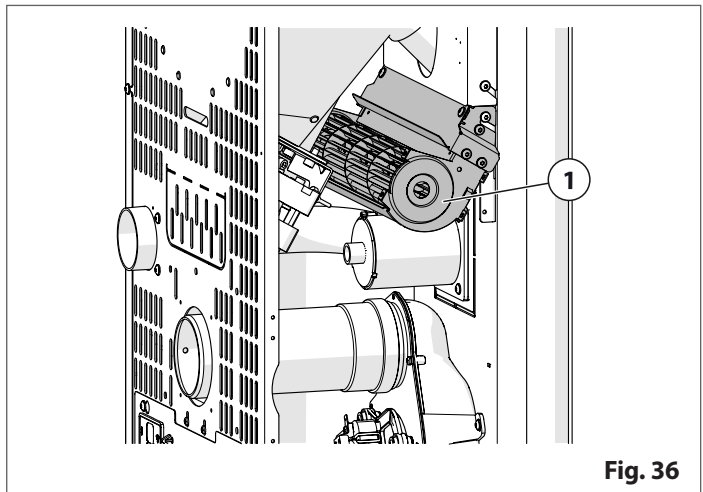

Fig. 36

### 10.11 CLEANING THE SMOKE OUTLET

The frequency with which the smoke outlet is to be cleaned depends on how much the appliance gathers dirt.

**i** Recommended cleaning frequency: refer to the section "SCHEDULED MAINTENANCE".  
 ■ Please refer to and carefully read the section "FLUE PIPE".

**!** Cleaning must only be carried out by a T.A.C. (Technical Assistance Centre) or a qualified technician.

#### "TEE" connector

Proceed as follows:

- Remove the plug from the "TEE" fitting (1) and clean the pipes

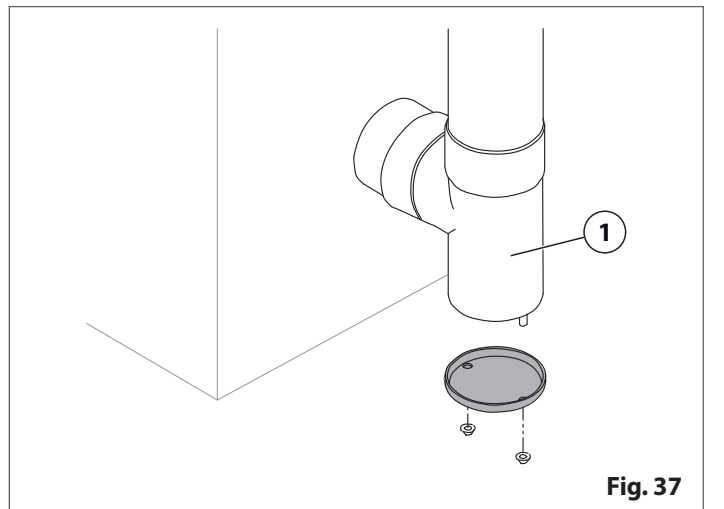

Fig. 37

## 10.12 REPLACING THE FUSES

**!** Please contact a T.A.C. (Technical Assistance Centre) or qualified technician for any work requiring access to the inside of the cladding or to any electrical or electronic parts.

### FUSE ON THE POWER CABLE SOCKET

Proceed as follows:

- extract the fuse box drawer (1) in the power socket
- replace the fuse with the spare to be found inside the small drawer or with another fuse of the same type

Type of fuse: 5x20 F4AL250V

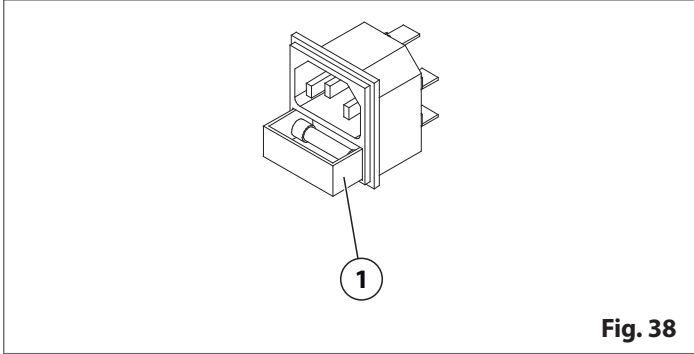

Fig. 38

## 11 WHEN NOT IN USE

When shutting the appliance down at the end of the season or if a long period of inactivity is anticipated, proceed as follows:

- remove all pellets from the appliance
- carry out all the operations described in the section "*CLEANING AND MAINTENANCE*" so as to prevent deposits which would damage the product and would be difficult to remove when the appliance is next used
- ensure that checks, cleaning and maintenance operations not only on the appliance itself but also on the entire system (flue gas pipe, fresh air intake and suction pipes, hot air ducting, water-heating system etc) are carried out by specialised and qualified technicians
- if the product is equipped with a remote control, remove the batteries from the remote control unit to prevent any oxidation
- disconnect the product and /or any installed accessories from the electrical power source.

**!** For appliances fitted with a boiler, if you disconnect the power supply, some of the appliance functions are not available or active (e.g. the circulator anti-block function and the anti-freeze function).

### To remove all pellets, proceed as follows:

- remove the pellets which are in the hopper, as far as the protection grille, when the fire is out and the appliance is completely cold
- switch on the appliance, allow it to operate until all the pellets have been depleted and the appliance switches off
- wait for the appliance to cool down completely.

**i** Excessive humidity and a long period of inactivity may cause the formation of rust on some of the unpainted parts inside the product.

- This is a natural situation and does not compromise the efficiency or life of the product and is not to be considered a defect.

**i** After a period of inactivity, the problem of expansion of the materials and emission of vapours could recur. Refer to the section "*NOTES REGARDING THE FIRST START-UP*".

## 12 DISPOSAL OF PRODUCT AT END OF PRODUCT LIFE

The owner is exclusively responsible for destroying and disposing of the product in compliance with the regulations in force as regards safety and respecting/protecting the environment.

**Contact the relevant authorities for information regarding local regulations.**

**Contact a qualified technician to definitively take the product out of service.**

Before uninstalling the appliance:

- disconnect the electrical power supply (for electrical appliances)
- ensure all system components and connections are safe
- shut off all boiler and system connections (for appliances fitted with a boiler)
- shut off the appliance gas inlet valve (for gas appliances)

**Disposing of this appliance incorrectly may cause environmental damage or harm human health.**

**The appliance and accessories must not be disposed of with normal household waste. Dispose of the appliance at a waste recycling centre.**

### 12.1 ELECTRICAL AND ELECTRONIC WASTE



When the symbol is shown on the appliance, accessories, packaging or documentation, this indicates that the appliance, accessories, batteries/accumulators and any related electrical/electronic parts **MUST NOT** be disposed of as normal household waste. Instead, they must be taken to a suitable recycling centre for electrical and electronic appliances.

Disposing of these items incorrectly may cause environmental damage or harm to human health.

You can ask your local retailer collect your electrical or electronic waste according to the terms and conditions stated in the national regulations transposing EU Directive 2012/19/EU.

Contact the relevant authorities for information regarding local regulations.



## 13 REFERENCE STANDARDS

### Country of application: The European Union

EN 14785	Residential space heating appliances fired by wood pellets - Requirements and test methods
EN 60335-1	Household and similar electrical appliances. Safety - Part 1: General requirements
EN 60335-2-102	Household and similar electrical appliances. Safety - Part 2-102: Particular requirements for gas, oil and solid-fuel burning appliances having electrical connections
EN 1443	Chimneys - General requirements
EN 1457-1	Chimneys - Clay/ceramic flue liners - Part 1: Flue liners operation under dry conditions – Requirements and test methods
EN 1457-2	Chimneys - Clay/ceramic flue liners - Part 2: Flue liners operating under wet conditions - Requirements and test methods
EN 1806	Chimneys - Clay/ceramic flue blocks for single wall chimneys - Requirements and test methods
EN 1856-1	Chimneys - Requirements for metal chimneys - Part 1: System chimney products
EN 1856-2	Chimneys - Requirements for metal chimneys - Part 2: Metal flue liners and connecting flue pipes
EN 13384-1	Chimneys - Thermal and fluid dynamic calculation methods - Part 1: Chimneys serving one appliance
EN 15287-1	Chimneys - Design, installation and commissioning of chimneys - Part 1: Chimneys for non-roomsealed heating appliances
EN 15287-2	Chimneys - Design, installation and commissioning of chimneys - Part 2: Chimneys for roomsealed appliances
EN 13501-1	Fire classification of construction products and building elements - Part 1: Classification using data from reaction to fire tests
EN ISO 17225-1	Solid biofuels - Fuel specifications and classes - Part 1: General requirements
EN ISO 17225-2	Solid biofuels - Fuel specifications and classes - Part 2: Graded wood pellets

 **The installation of the product must be made in accordance with the manufacturer's instructions and in compliance with local regulations. Contact the fire service or competent authorities for clarifications on the restrictions and requirements in your area.**

## 14 APPENDIX

### Identification data plate: key



Please read and comply with the instructions for installation, use and maintenance.

**Model** = Model

**Type** = Type

**DoP** = Declaration of performance

**N.Body** = Notified body

**Pn** = Nominal heat output

**Pp** = Part load heat output

**Pnom** = Nominal space heat output

**Ppart** = Part load space heat output

**Pwnom** = Nominal water heat output

**Pwpart** = Part load water heat output

**Pinnom** = Nominal heat input

**Pinpart** = Part load heat input

**ηnom** = Efficiency at nominal heat output

**ηpart** = Efficiency at part load heat output

**pnom** = Minimum flue draught at nominal heat output

**ppart** = Minimum flue draught at part load heat output

**Tnom** = Flue gas outlet temperature at nominal heat output

**Tpart** = Flue gas outlet temperature at part load heat output

**Tfg,nom** = Flue gas temperature at nominal heat output

**Tfg,part** = Flue gas temperature at part load heat output

**CO<sub>nom</sub> (13% O<sub>2</sub>)** = CO emission at 13% oxygen content at nominal heat output

**CO<sub>part</sub> (13% O<sub>2</sub>)** = CO emission at 13% oxygen content at part load heat output

**CO<sub>nom</sub>** = CO emission at 0% oxygen content at nominal heat output

**CO<sub>part</sub>** = CO emission at 0% oxygen content at part load heat output

**NO<sub>xnom</sub> (13% O<sub>2</sub>)** = NO<sub>x</sub> emission at 13% oxygen content at nominal heat output

**NO<sub>xpart</sub> (13% O<sub>2</sub>)** = NO<sub>x</sub> emission at 13% oxygen content at part load heat output

**NO<sub>xnom</sub>** = NO<sub>x</sub> emission at 0% oxygen content at nominal heat output

**OGC<sub>nom</sub> (13% O<sub>2</sub>)** = Hydrocarbon emission at 13% oxygen content at nominal heat output

**OGC<sub>part</sub> (13% O<sub>2</sub>)** = Hydrocarbon emission at 13% oxygen content at part load heat output

**OGC<sub>nom</sub>** = Hydrocarbon emission at 0% oxygen content at nominal heat output

**OGC<sub>part</sub>** = Hydrocarbon emission at 0% oxygen content at part load heat output

**PM<sub>nom</sub> (13% O<sub>2</sub>)** = Particulate matter emission at 13% oxygen content at nominal heat output

**PM<sub>part</sub> (13% O<sub>2</sub>)** = Particulate matter emission at 13% oxygen content at part load heat output

**PM<sub>nom</sub>** = Particulate matter emission at 0% oxygen content at nominal heat output

**W<sub>max</sub>** = Maximum electrical power input

**E, f** = Rated Voltage - Rated Frequency

**dout** = Diameter of the flue gas outlet

**L, H, W** = Overall dimension of the appliance

**pw** = Maximum operating pressure

**Tw<sub>max</sub>** = Maximum allowable temperature (water)

**dR** = minimum clearance distances from the rear to combustible material

**dS** = minimum clearance distances from the sides to combustible material

**dP** = minimum clearance distances from the front to combustible material

(\*) = This appliance complies with the requirements

**MUL** = Suitable for shared flue chimney (if permitted by national regulations and local laws)

**INT** = Suitable for intermittent combustion

**(a)** = 2.BImSchV (Germany)

**(b)** = 15a B-VG (Austria)

**(c)** = LRV/Opair (Swiss)

**(d)** = BAFA (Germany)

Blank page with horizontal dashed lines for writing.



Via Montello, 22  
31011 Asolo (TV) - ITALY  
Tel. +39.04235271 - Fax +39.042355178  
[www.superiorstufe.com](http://www.superiorstufe.com)  
e-mail: [info@superiorstufe.com](mailto:info@superiorstufe.com)